

Vacuum Measurement Instrumentation

Rough and Medium Vacuum Gauges



Passive Sensors



Active Vacuum Gauges



Display and Control Units for
Active Vacuum Gauges



Measurement Instrumentation for
High and Ultra High Vacuum



Vacuum Measurement Instrumentation - Product Overview

Model	Page	Measurement / Display Range	Device Type
10^3 mbar / torr			
Rough and Medium Vacuum Gauges, Passive Sensors			
RFM	8-10	■ ■	Bourdon gauge
DVR2	8-11	■ ■ ■	Capacitance diaphragm gauge w. integrated sensor & display
DCP 3000	8-12	■ ■ ■ ■	Capacitance diaphragm gauge for 1 to 4 transducers
DIGITAL VT	8-13	■ ■ ■ ■	Vacuum gauge meter for DV series thermocouple sensors
DV Series	8-14	■ ■ ■ ■	Thermocouple sensors
VGC-301	8-15	■ ■ ■ ■ ■	Convection vacuum gauge controller
CVG-101	8-16	■ ■ ■ ■ ■ ■	Convection-enhanced Pirani gauge
GP 275 Convectron	8-17	■ ■ ■ ■ ■ ■	Convection-enhanced Pirani gauge
10^3 mbar / torr			
Active Vacuum Gauges			
HPM 760S	8-18	■ ■ ■ ■	Piezo vacuum transducer module
CERAVAC CTR 100 / 91	8-19	■ ■ ■ ■ ■ ■	Ceramic capacitance gauge (4 decades per gauge version)
THERMOVAC TTR 91	8-20	■ ■ ■ ■ ■ ■	Pirani gauge
CVM-211	8-21	■ ■ ■ ■ ■ ■	Convection-enhanced Pirani gauge module with display
CVM-201	8-22	■ ■ ■ ■ ■ ■	Convection-enhanced Pirani gauge module with display, etc.
THERMOVAC TTR 100	8-23	■ ■ ■ ■ ■ ■	Combined Pirani / capacitance vacuum gauge
PENNINGVAC PTR 225 / 237	8-24	■ ■ ■ ■ ■ ■ ■ ■	Cold cathode ionisation vacuum gauge (inverted magnetron)
IGM-401	8-25	■ ■ ■ ■ ■ ■ ■ ■	Hot cathode ionisation vacuum gauge module with display
ATMION Compact / Standard	8-26	■ ■ ■ ■ ■ ■ ■ ■ ■ ■	Wide range Pirani / Bayard-Alpert vacuum gauge
10^3 mbar / torr			
Display and Control Units for Active Vacuum Gauges			
THPS 760 PLUS	8-28	■ ■ ■ ■	Vacuum controller for HPM 760S piezo transducer
DISPLAY ONE	8-28	■ ■ ■ ■ ■ ■	Display and operating unit for THERMOVAC TTR 90/91
ATMIGRAF	8-29	■ ■ ■ ■ ■ ■ ■ ■	Display and operating unit for ATMION wide range gauges
MVC3-A, MVC3-0	8-30	■ ■ ■ ■ ■ ■ ■ ■ ■ ■	Multi-channel vacuum controller for 1 to 3 active gauges (ATMION, CTR, TTR, PTR, CVM)
10^3 mbar / torr			
Measurement Instrumentation for High and Ultra High Vacuum			
<i>(all controllers offer option. channels for fore-vacuum gauges)</i>			
MVC3-B	8-31	■ ■ ■ ■ ■ ■ ■ ■ ■ ■	UHV controller for BAIS UHV gauge
BAIS	8-32	■ ■ ■ ■ ■ ■ ■ ■ ■ ■	UHV Bayard-Alpert-type gauge for MVC3-B controller
GP 307	8-33	■ ■ ■ ■ ■ ■ ■ ■ ■ ■	Modular vacuum gauge controller for 274 gauge series
GP 350	8-36	■ ■ ■ ■ ■ ■ ■ ■ ■ ■	UHV ionisation gauge controller for 274 gauge series
GP 274 Series	8-38	■ ■ ■ ■ ■ ■ ■ ■ ■ ■	Various HV / UHV Bayard-Alpert-type gauges
GP 370 STABIL ION	8-40	■ ■ ■ ■ ■ ■ ■ ■ ■ ■	Vacuum gauge controller for series 370 STABIL ION gauges
GP STABIL ION Gauges	8-41	■ ■ ■ ■ ■ ■ ■ ■ ■ ■	HV / UHV Bayard-Alpert-type gauges, 360 and 370 series
<p>■ Measurement range</p> <p>■ Measurement range dependent on gauge version</p> <p>■ Display range</p>			

Rough and Medium Vacuum Gauges, Passive Sensors

RFM Bourdon gauge

Bourdon gauge for visual control of forelines and evacuation processes at low vacuum



RFM standard



RFMC corrosion resistant

- Reliable
- Cost effective
- Compact
- 2 Versions: standard and corrosion resistant

Technical data:

- | | |
|-------------------------|---|
| ■ Measurement range | 1020 to < 10 mbar |
| ■ Measurement principle | tube gauge according to Bourdon standard: plastics, black |
| ■ Housing | corrosion resistant: stainless steel |
| ■ Materials in vacuum | standard: copper alloy |
| | corrosion resistant: stainless steel |
| ■ Weight | approx. 0.2 kg |
| ■ Protection category | corrosion resistant: IP65 |

Order code	Vacuum connection	Version	D	H
RFMK	DN16KF	standard	79	115
RFMG	G 1/4" B	standard	79	115
RFMCK	DN16KF	corrosion resistant	63	78
RFMCG	G 1/4" B	corrosion resistant	63	78

8

DVR2 capacitance diaphragm gauge

Battery-operated gauge with integrated capacitive pressure transducer for low vacuum

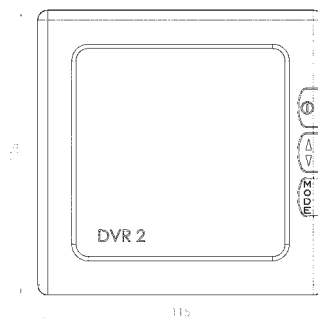

Technical Data

- | | |
|---------------------------|--|
| ■ Measurement range | 1080 to 1 mbar |
| ■ Measurement principle | capacitance gauge with aluminium oxide diaphragm |
| ■ Accuracy | < 1 mbar ±1 digit |
| ■ Temperature coefficient | < 0.07 mbar / K |
| ■ Display | LCD, digital and analog |
| ■ Units | mbar, hPa, Torr (user selectable) |
| ■ Measurement cycle | automatical, 3 s, 1 s, 1/3 s |
| ■ Operating temperature | 10 to 60 °C |
| ■ Materials in vacuum | aluminium oxide ceramics, stainless steel |
| ■ Max. media temperature | 80 °C at the pressure transducer |
| ■ Vacuum connection | flange DN16KF with stepped screw-in hose nozzle DN6/10 |
| ■ Power supply | 9 V lithium battery |
| ■ Housing | rugged plastic housing (PP) |
| ■ Weight | 0.4 kg |

Order code	Description
VB-682902	DVR2 (battery incl.)
VB-612220	Replacement battery block 9 V lithium 1.2 Ah
VB-900216	DKD-calibration (for new gauges)
VB-900217	DKD-recalibration

DCP 3000 capacitance diaphragm gauge

Vacuum gauge for 1 to 4 capacitive pressure transducers and 1 vent valve, with analog and digital display and serial interface

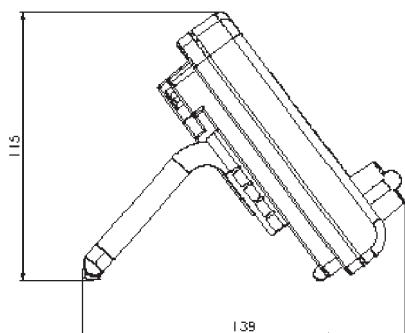
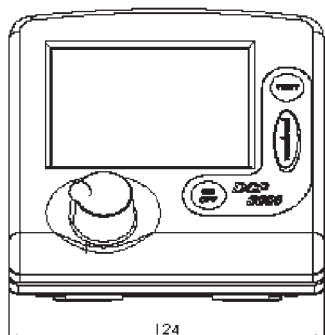

Technical data

- Measurement channels 4
- Measurement range 1080 to 0.1 mbar
- Measurement principle capacitance gauge with aluminium oxide diaphragm, temperature compensated
- Accuracy $< \pm 1$ mbar (0.75 Torr) (calibrated, at constant temperature)
- Temperature coefficient $< \pm 0.07$ mbar / K (0.5 Torr/K)
- Display graphical LCD with analog trend indicator, 5-digit display and indication of the active measurement channel (or alternatively digital display of all 4 channels)
- Units mbar, Torr, hPa (user selectable)
- Switching function 1 optional vent valve with VACUU.BUS-cable
- Interface RS-232C
- Pressure transducer VSK 3000, sensor made of aluminium oxide ceramics (high purity)
- Materials in vacuum aluminium oxide ceramics, PPS (sensor fixing) aluminium (housing; stainless steel on request), highly durable fluor elastomere
- Vacuum connection flange DN16KF aluminium, fitting for PTFE-tube 10/8 mm and enclosed screw-in PP-hose nozzle 6/10 mm
- Power supply 90 - 264 V AC, 47 - 63 Hz, 0.8 A
- Weight pressure transducer: 0.18 kg, gauge without power supply: 0.44 kg wall power supply: 0.24 kg
- Scope of delivery gauge DCP 3000, 1 sensor VSK 3000, wall power supply with exchangeable plugs for EU, UK, USA, AU; manual
- Connectable sensors VSK 3000
- Connectable vent valve 24 V DC - vent valve with VACUU.BUS-cable

Order code	Description
VB-683170	Capacitance gauge DCP 3000 with 1 sensor VSK 3000
VB-636657	Sensor VSK 3000
VB-674217	External vent valve VB M-B, 24 V DC, with VACUU.BUS-cable
VB-612566	VACUU.BUS-cable for conversion of other 24 V DC-vent valves
VB-900214	DKD calibration (for new gauges)
VB-900215	DKD recalibration

Rough and Medium Vacuum Gauges, Passive Sensors

DIGITAL VT vacuum gauge meter

Vacuum gauge meter for passive thermocouple sensors series DV



Technical data

- Measurement channels 1
- Measurement range VT-4: 20 to 0.1 Torr
VT-6: 999 to 1 mTorr
- Typical accuracy VT-4: $\pm(30\% \text{ of reading} + 0.02 \text{ Torr})$
VT-6: $\pm(15\% \text{ of reading} + 1 \text{ mTorr})$
- Temperature coefficient VT-4: $\pm(1\% \text{ of reading} + 2 \text{ mTorr}) / ^\circ\text{C}$
VT-6: $\pm(1\% \text{ of reading} + 0.2 \text{ mTorr}) / ^\circ\text{C}$
- Display LED, 3-digit, green
- Units Torr / mTorr
- Operating temperature 5 to 50 °C
- Power supply 4.5 to 5.3 V DC / 155 mA or 90-240 VAC, 50/60 Hz, 2W with included power converter
- Housing plastics, 1/8 DIN, suitable for panel mounting
- Weight 0.2 kg
- Scope of delivery gauge meter, power converter 90 - 240 V AC, 2 m power cable, 2.5 m sensor cable (other lengths on request). Please order sensor separately

■ Connectable sensors

series DV-4 (20 to 0.1 Torr)
series DV-6 (999 to 1 mTorr)
see page 8-14

Order code	Description
55-288DV4	Digital VT-4 (20 Torr), Power converter, power cable (US-plug), sensor cable
55-288DV6	Digital VT-6 (999 mTorr), Power converter, power cable (US-plug), sensor cable
12-01-165	AC-plug for UK Service
12-01-164	AC-plug for European Service

DV series thermocouple sensors

Passive heat loss sensors for rough and medium vacuum

Technical data

- Measurement range DV-4: 20 to 0.1 Torr
DV-6: 999 to 1 mTorr
- Most sensitive range DV-4: 5 to 0.2 Torr
DV-6: 200 to 10 mTorr
- Measurement principle heat loss gauge with thermocouple
- Materials in vacuum nickel-plated steel, stainless steel, glass, noble metal thermocouple
- Mounting orientation arbitrary
- Weight 0.05 to 0.15 kg
- Operating units DIGITAL VT, GP 307



Order code		Vacuum connection*
DV-6M (yellow)	DV-4D (purple)	standard 1/8" NPT
DV-6R	DV-4R	ruggedized 1/8" NPT
DV-6M-KF-16	DV-4D-KF-16	DN16KF
DV-6M-KF-25	DV-4D-KF-25	DN25KF
DV-6M-VCR	DV-4D-VCR	VCR
DV-20	-	glass 3/8" (O.D.)
DV-6R-CF	-	Mini Conflat® 1.33" CF
DV-36	DV-34	stainless steel 1/8" NPT
DV-36 smooth	-	stainless steel, smooth ends
DB-20	DB-16D	reference sensor (NIST traceable)

Sensor cable: included in DIGITAL VT gauge meter (p. 8-13).
Extension sensor cables on request.

VGC-301 convection vacuum gauge controller

Vacuum controller for passive convection-enhanced Pirani gauges, with analog output, setpoints and serial interfaces

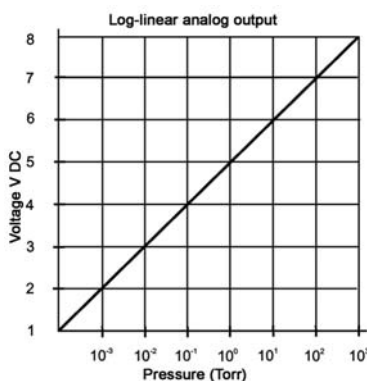
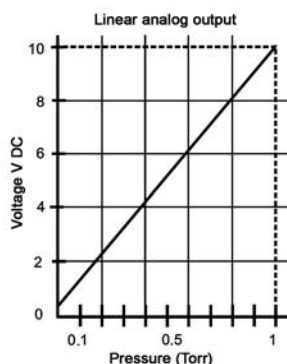
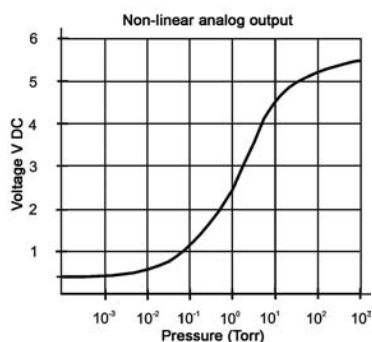

- Wide measurement range, high resolution
- Cost-effective, functional
- For CVG-101 and GP 275 Convector® sensors
- Configurable analog output
- Two setpoint relays
- Two serial interfaces

Technical data

- Measurement channels 1
- Measurement range 1333 to 1×10^{-4} mbar
- Resolution 1×10^{-4} mbar
- Display LCD, 4-digit
- Units mbar, Pa, Torr (user selectable)
- Update rate 0.5 s
- Analog output user selectable
 - a) non-linear 0.375 to 5.659 V DC
 - b) linear 0 to 10 V DC, scalable
 - c) log-linear 1 to 8 V DC (1 V / decade)
- Setpoints 2 relays, 30 V DC / 1 A
- Interfaces RS-232 / RS-485
- Operating temperature 0 to 40 °C
- Power supply 100 to 240 V AC, 50/60 Hz or 12 to 30 V DC
- Housing aluminium, 1/8 DIN, suitable for panel mounting
- Weight 0.25 kg
- Scope of delivery controller with 1.5 m EC-power cable (please order sensors and sensor cables separately)
 - CVG-101 (page 8-16)
 - GP 275 Convector® (page 8-17)

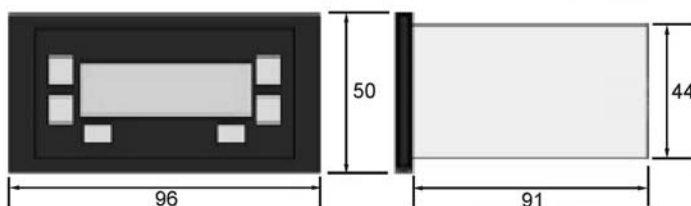

Order code	Description
VGC301A-EU	Controller for convection Pirani sensor
CB421-1-10F	Sensor cable 3 m
CB421-1-25F	Sensor cable 8 m
CB421-1-50F	Sensor cable 15 m

Larger cable length on request.

- Convection Pirani sensors CVG-101 see page 8-16

CVG-101 convection-enhanced Pirani gauge

Passive heat loss gauge with convection enhancement for rough and medium vacuum



- Completely redesigned convection Pirani sensor
- Cost-effective and rugged
- Wide measurement range with high accuracy and repeatability
- Convection enhancement provides high accuracy at rough vacuum
- Reliable process control (evacuation, venting) with only one sensor
- Short response time
- Best accuracy at horizontal mounting position
- Sensors and controllers are interchangeable without previous calibration
- Compatible with GP 275 Convectron® sensors
- Replacement sensor for InstruTech CVM-201

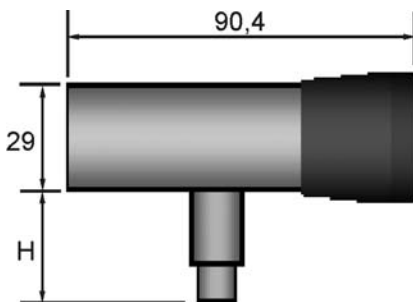

Technical data

- Measurement range: 1330 to 1×10^{-4} mbar
- Measurement principle: thermal conductivity gauge according to Pirani with convection enhancement
- Accuracy (typical): $\pm 2\%$ from atm. to 500 mbar, $\pm 10\%$ from 500 to 1×10^{-3} mbar
- Operating temperature: 0 to 50 °C
- Bake-out temperature: max. 150 °C without cable
- Materials in vacuum: tungsten (gold-plated), stainless steel, glass, nickel, Teflon®
- Housing: stainless steel with plastic enclosure
- Mounting orientation: below 1 mbar arbitrary, above 1 mbar horizontal sensor axis recommended
- Weight: approx. 0.085 kg (without flange)
- Operating units: VGC-301, GP 307, GP 350, GP 370

Order code standard sensor	Order code replacement sensor for CVM-201	Vacuum connection	H (mm)
CVG101GA	CVG102GA	1/8" NPT / 1/2" tube	25.4
CVG101GB	CVG102GB	DN16KF	33
CVG101GC	CVG102GC	DN25KF	33
CVG101GD	CVG102GD	DN40KF	33
CVG101GE	CVG102GE	DN16CF	27.4
CVG101GF	CVG102GF	DN35CF	21.6
CVG101GG	CVG102GG	1/4" VCR screw connection, female	47.2
CVG101GH	CVG102GH	1/2" VCR screw connection, female	44.5

Accessories

Order code	Description
CK431-01	cable plug

- Measurement cables see VGC-301, page 8-15

GP 275 Convector® convection-enhanced Pirani gauge

Passive heat loss gauge with convection enhancement for rough and medium vacuum



- Industry standard, reliable, rugged
- Wide measurement range with high accuracy and repeatability
- Convection enhancement provides high accuracy at rough vacuum
- Reliable process control (evacuation, venting) with only one sensor
- Short response time
- Best accuracy at horizontal mounting position
- Replacement sensor for GPMini-Convector® modules

Technical data

- | | |
|--|--|
| <ul style="list-style-type: none"> ■ Measurement range ■ Measurement principle | <p>1330 to 1×10^{-4} mbar
thermal conductivity gauge according to Pirani with convection enhancement</p> |
| <ul style="list-style-type: none"> ■ Accuracy (typical) | <p>$\pm 2\%$ from atm. to 500 mbar
$\pm 10\%$ from 500 to 1×10^{-3} mbar</p> |
| <ul style="list-style-type: none"> ■ Operating temperature ■ Bake-out temperature ■ Materials in vacuum | <p>15 to 50 °C
max. 150 °C/105 °C with cable
tungsten (gold-plated), stainless steel, glass, nickel, PTFE</p> |
| <ul style="list-style-type: none"> ■ Housing ■ Mounting orientation | <p>stainless steel
below 1 mbar arbitrary, above 1 mbar horizontal sensor axis recommended</p> |
| <ul style="list-style-type: none"> ■ Weight ■ Operating units | <p>approx. 0.1 kg (without flange)
VGC-301, GP 307, GP 350, GP 370</p> |

Order code standard sensor	Order code replacement sensor for Mini-Convector® Modules	Vacuum connection
275071	275810	1/8" NPT / 1/2" tube
275203	275816	DN16KF
275196	275817	DN25KF
275316	275818	DN40KF
275256	275813	DN16CF
275238	275814	DN35CF
275186	275811	1/4" VCR screw connection, female
275282	275864	1/2" VCR screw connection, female

- Measurement cable see VGC-301, page 8-15

HPM 760S piezo vacuum transducer module

Active, temperature compensated piezo-resistive diaphragm sensor for rough vacuum

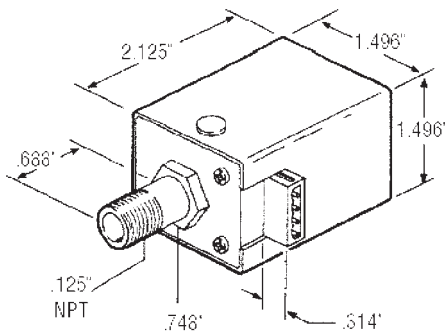

- Rugged piezo-resistive transducer on a silicon chip which includes sealed vacuum reference, temperature compensation and bridge circuit
- Gas-type-independent measurement
- For use in process control
- Economical alternative to higher cost systems
- High stability, accuracy and reproducibility
- Zero and span adjustable
- Compact size
- Linear analog output (voltage or current)

Technical data

- Measurement range 1000 to 0.1 Torr
- Measurement principle Diaphragm gauge with piezo-resistive sensor, temperature compensated
- Accuracy 0.25 % F.S.
- Response time < 2 s
- Operating temperature 0 to 50 °C
- Materials in vacuum stainless steel 316L,
- Analog output linear 0 to 10 V DC, 0 to 5 V DC, 4 to 20 or 2 to 10 mA
- Power supply 15 to 30 V DC / 15 mA at 24 VDC (no load)
- Electrical connection 4-pin plug (included)
- Weight 0.3 kg
- Operating units THPS 760 Plus

Structure of order code:

sensor type-output-vacuum connection
e.g. HPM760S-01-A

Order code	Output	Option	Vacuum connection	Option
HPM760S-*-*	0 - 5 V DC	-01	1/8" NPT	A
	0 - 10 V DC	-02	DN16KF	B
	2 - 10 mA	-03	DN25KF	C
	4 - 20 mA	-04	VCR4	D

Sensor cable see THPS-760 Plus page 8-28

CERAVAC CTR 100, CTR 91 ceramic capacitance gauge

Active, temperature compensated and temperature controlled capacitance diaphragm gauges, for rough and medium vacuum



- Multi-purpose sensors with aluminium oxide diaphragm for gas-type independent measurement
- Excellent accuracy and reproducibility, high resolution
- Short response time
- Corrosion resistant, suitable for corrosive processes
- Excellent temperature stability
- Compared to metal diaphragm gauges reduced sensor-to-sensor variation, improved long-term stability, reduced diaphragm reset time
- Applicable as reference sensor for other gauges in accordance with DIN/ISO 9000
- Linear analog output
- Operating units: MVC3, see page 8-30/8-31

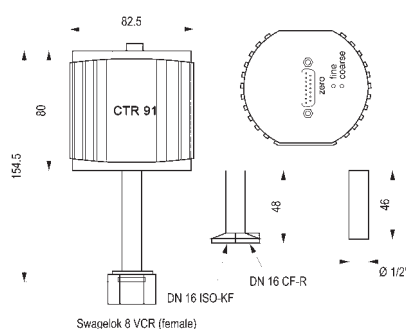
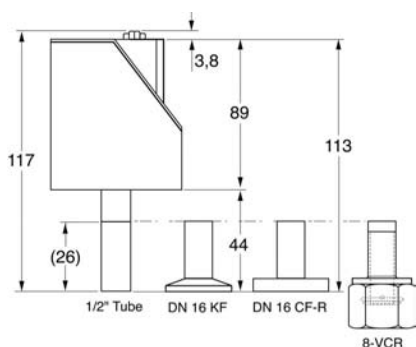

Technical data	CTR 100	CTR 91
Measurement range	0.1 to 1×10^{-5} Torr (only CTR91); 1 to 1×10^{-4} Torr; 10 to 1×10^{-3} Torr; 100 to 0.01 Torr; 1000 to 0.1 Torr	
Measurement principle	capacitance gauge with aluminium oxide diaphragm temperature compensated temperature controlled (45°C)	
Accuracy	0.2 % of reading \pm thermal shift	0.15 % of reading \pm thermal shift (1, 10, 100, 1000 Torr); 0.2 % of reading \pm temperature shift (0.1 Torr)
Resolution	0.003 % F.S.	0.0015 % F.S. (10; 100; 1000 Torr) 0.0025 % F.S. (0.1; 1 Torr)
Thermal zero shift	0.015 % / °C F.S. for 1 Torr 0.005 % / °C F.S. 10; 100; 1000 Torr	0.005 % / °C F.S. (0.1 Torr) 0.0025 % / °C F.S. (1; 10; 100; 1000 Torr)
Thermal span shift	0.01 % / °C of reading	
Response time	≤ 30 ms	
Operating temperature	5 to 50 °C	15 to 40 °C
Materials in vacuum	aluminium oxide, stainless steel 316, Vacon 70	
Analog output	linear, 0 to 10 V DC	
Power supply	+14 to +30 V DC (1 W)	± 15 V DC or +24 V DC (< 19 W)
Electrical connection	15-pin Sub-D plug	
Weight	0.26 kg	0.60 kg
Operating units	MVC3	

Structure of order code

sensor type + vacuum connection + pressure range, e.g. CCK3

Order code	Sensor Type
CC**	temperature compensated
CCT**	temperature controlled

Vacuum connection	Option	Pressure range	Option
DN16KF	K	1000 Torr (F.S.)	3
DN16CF-R	C	100 Torr (F.S.)	2
VCR8	V	10 Torr (F.S.)	1
1/2" tube	without code	1 Torr (F.S.)	0
		0.1 Torr (F.S.)(only CCTK)	-1

THERMOVAC TTR 91, TTR 91 S Pirani gauge

Active thermal conductivity gauge, for rough and medium vacuum, with optional setpoint



- Compact and rugged design
- Stable vacuum measurement over a wide operating temperature range due to optimized temperature compensation
- Short response time
- Resistant to reasonable overpressure
- Replaceable sensor unit
- Log-linear analog output

Technical data

- | | |
|-------------------------|---|
| ■ Measurement range | 1000 to 5×10^{-4} mbar |
| ■ Measurement principle | thermal conduction according to Pirani, temperature compensated |
| ■ Accuracy | $\pm 15\%$ between 100 to 1×10^{-3} mbar |
| ■ Reproducibility | 2 % between 100 to 1×10^{-3} mbar |
| ■ Response time | 10 ms |
| ■ Operating temperature | 10 to 50 °C |
| ■ Bake-out temperature | KF connection: 80 °C at the flange
CF connection: 250 °C at the flange |
| ■ Materials in vacuum | stainless steel, W, glass, Ni, Cu, NiFe |
| ■ Analog output | log-linear, 1.9 to 10 V DC |
| ■ Setpoint | 1 relay, max. 60 V DC / 0.5 A (optional) |
| ■ Power supply | 14 to 32 V DC, ≤ 1 W |
| ■ Electrical connection | FCC-68 female, 8-pin with shield |
| ■ Weight | 0.15 kg |
| ■ Protection category | IP40 |
| ■ Operating units | DISPLAY ONE, MVC3 |

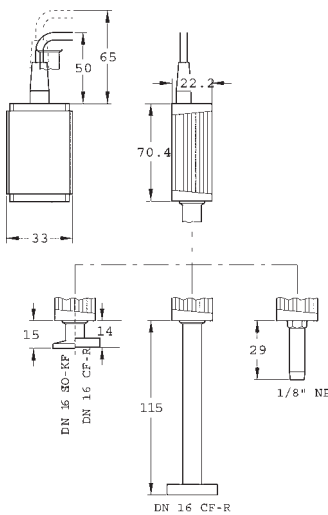

Order code	Series	Vacuum connection	Switchpoint
LH-230035	TTR91	DN16ISO-KF	no
LH-230036		DN16CF-R	no
LH-230037		DN16CF-R*	no
LH-230038		1/8" NPT	no
LH-230040	TTR91S	DN16ISO-KF	yes
LH-230041		DN16CF-R	yes
LH-230042		DN16CF-R*	yes
LH-230043		1/8" NPT	yes

* NW16CF-R long tube

CVM-211 convection-enhanced Pirani gauge module

Active heat loss gauge with convection enhancement, for rough and medium vacuum, with display and setpoint

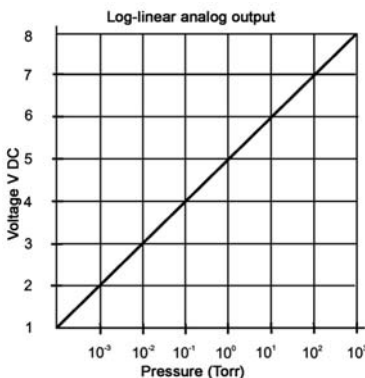
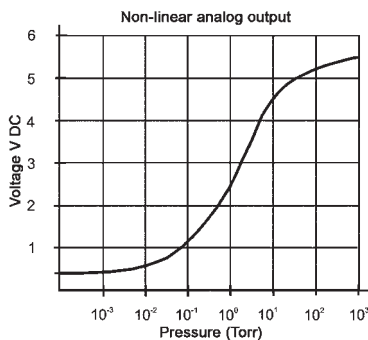
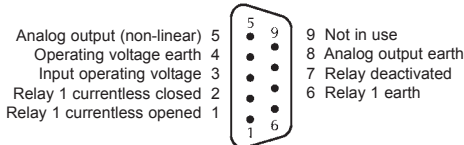
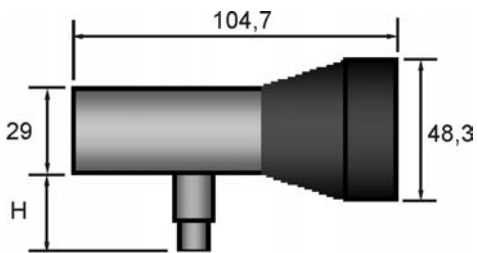

- Completely redesigned convection Pirani sensor
- Simple, competitive and rugged solution for versatile application
- Economic upgrade for thermocouple gauges, offering improved measurement range and accuracy
- Wide measurement range with high accuracy and reproducibility
- Convection enhancement provides high accuracy at rough vacuum
- Reliable process control (evacuation, venting) with only one sensor
- Short response time
- Best accuracy at horizontal mounting position
- Easy setup and operation
- Built-in digital display is invaluable during system fabrication and maintenance
- Two analog output signal versions
- Compatible with GP Mini-Convectron® basic modules

Technical data

- Measuring range 1330 to 1 x 10⁻⁴ mbar
- Measuring principle thermal conductivity gauge according to Pirani with convection enhancement
- Accuracy (typical) ±2 % from atm. to 500 mbar
±10 % from 500 to 1 x 10⁻³ mbar
- Display 3-digit LED, red
- Units bar / mbar
- Operating temperature 0 to 40 °C
- Bake-out temperature max. 70 °C
- Materials in vacuum tungsten (gold-plated), stainless steel, glass, nickel, Teflon®
- Mounting orientation below 1 mbar arbitrary, above 1 mbar horizontal sensor axis recommended
- Analog output a) non-linear 0.375 to 5.659 V DC or, b) log-linear 1 to 8 V DC
- Setpoint 1 relay, 30 V DC / 1 A
- Power supply 11 to 30 V DC
- Electrical connection 9-pin Sub-D plug
- Weight 0.14 kg
- Operating units MVC3

Order code		Vacuum connection*	H (mm)
Analog output			
non-linear	log-linear		
CVM211GBA-B-NL	CVM211GBA-B-L	DN16KF	33
CVM211GEA-B-NL	CVM211GEA-B-L	DN16CF	37.3

* other vacuum connections on request

Accessories for active Pirani sensors CVM-211 and CVM-201

Order code	Description
PS-12VDC-SUBD9	Power supply 100/230 V AC 12 V DC
PS402-A	Battery power supply (2 x 9 V), plug-on

CVM-201 convection-enhanced Pirani gauge module

Active heat loss gauge with convection enhancement, for rough and medium vacuum, with graphical display, setpoints and serial interfaces

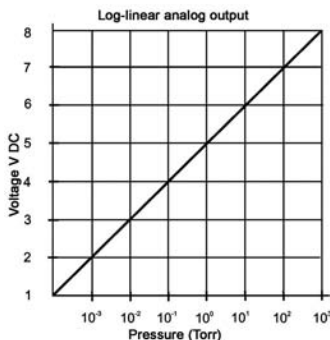
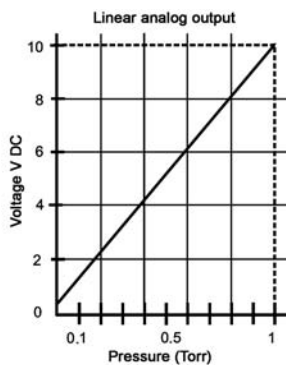
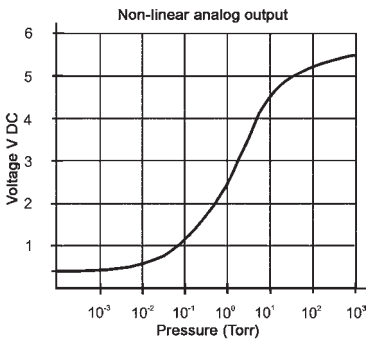
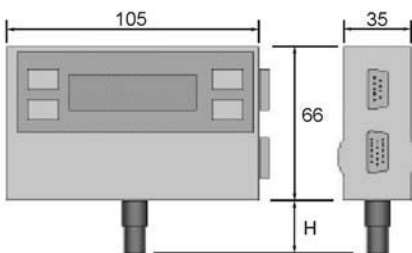

- Completely redesigned convection Pirani sensor
- Wide measurement range with high accuracy and reproducibility
- Reliable, rugged and cost-effective
- Convection enhancement provides high accuracy at rough vacuum
- Reliable process control (evacuation, venting) with only one sensor
- Best accuracy at horizontal mounting position
- Easy setup and operation
- Built-in digital display is invaluable during system fabrication and maintenance
- Configurable analog output signal
- Compatible with GP Mini-Convectron® modules

Technical data

- Measurement range 1330 to 1×10^{-4} mbar
- Measurement principle thermal conductivity gauge according to Pirani with convection enhancement
- Accuracy (typical) $\pm 2\%$ from atm. to 500 mbar
 $\pm 10\%$ from 500 to 1×10^{-3} mbar
- Display 4-digit graphical LCD
- Units mbar, Pa, Torr
- Operating temperature 0°C to 40°C
- Bake-out temperature max. 150°C (sensor without electronics)
- Materials in vacuum tungsten (gold-plated), stainless steel, glass, nickel, Teflon®
- Mounting orientation below 1 mbar arbitrary, above 1 mbar horizontal sensor axis recommended
- Analog outputs a) non-linear 0.375 to 5.659 V DC
b) linear 0 to 10 V DC, scalable
c) log-linear 1 to 8 V DC (1 V / decade)
- Interfaces RS-485 and RS-232
- Setpoints 2 relays, 30 V DC / 1 A
- Power supply 11 to 30 V DC
- Electrical connection 9-pin and 15-pin Sub-D plug
- Weight 0.34 kg

Order code	Vacuum connection*	H (mm)
CVM201GBA	DN16KF	29.5
CVM201GEA	DN16CF	34

* other vacuum connections on request

Replacement sensors see CVG-101 page 8-16,

Accessories see CVM-211 page 8-21

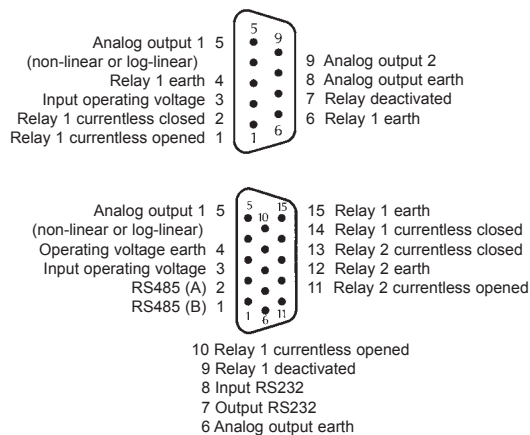

THERMOVAC TTR 100 combined Pirani / capacitance vacuum gauge

Active combination gauge with Pirani and ceramic capacitance sensor, for rough and medium vacuum, with optional setpoints



- Improved accuracy compared to standard Pirani sensors, as well as gas-type independent measurement between 1500 and 100 mbar
- Wide measurement range
- Short response time, shows the real pressure during fast evacuation / venting
- Arbitrary mounting orientation
- Flow independent
- Compact and rugged design
- Stable vacuum measurement over a wide operating temperature range
- Log-linear analog output

Technical data

- Measurement range 1500 to 5×10^{-4} mbar
- Measurement principle combination Pirani-/ ceramic capacitance gauge
- Accuracy $\pm 15\%$ from 950 to 50 mbar
 $\pm 5\%$ of reading from 50 to 1×10^{-3} mbar
- Reproducibility $\pm 2,5\%$ of reading at atm.
 $\pm 2\%$ of reading
- Response time 10 ms
- Operating temperature 10 to 50 °C
- Bake-out temperature 80 °C at flange
- Materials in vacuum stainless steel, W (Pirani sensor), Al_2O_3 (cap.sensor), glass, Ni, Cu, NiFe, SnAg, AgPd
- Analog output log-linear, 0 to 10.3 V DC
- Setpoints 2 relays (optional), max. 60 V DC/0.5 A
- Power supply 14 to 32 V DC / 2.5 W
- Electrical connection FCC-68 female, 8-pin with shield
- Weight 0.09 kg
- Protection category IP40
- Operating units MVC3

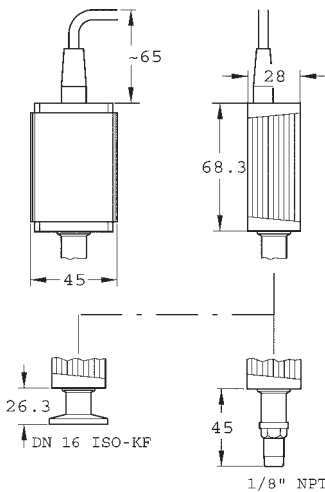

Order code	Series	Vacuum connection	Switchpoint
LH-230026	TTR100	DN16KF	no
LH-230028		1/8" NPT	no
LH-230027	TTR100S2	DN16KF	yes
LH-230029		1/8" NPT	yes

PENNINGVAC PTR 225, PTR 237 inverted magnetron gauge

Active cold cathode ionisation gauge for medium and high vacuum, with optional setpoint and optional Bus interfaces



- Easy to integrate into programmable control systems
- Rugged all-metal sensor cell
- Wide measurement range
- High reproducibility
- Good ignition characteristics due to optimised electrode design
- Low tendency for contamination (also during argon operation) due to high voltage reduction after plasma ignition and due to titanium cathodes
- Low magnetic stray field
- Simple installation and operation
- Log-linear analog output
- Optional with Profibus or DeviceNet interfaces

Technical data

- Measurement range 1 x 10⁻² to 1 x 10⁻⁹ mbar
- Measurement principle cold cathode ionisation gauge according to Penning (inverted magnetron)
- Accuracy ±30 % from 1 x 10⁻⁴ to 1 x 10⁻⁸ mbar
- Reproducibility ±2 % of reading
- Operating temperature 10 to 50 °C
- Bake-out temperature 250 °C without electronics (only PTR237)
- Materials in vacuum stainless steel, CrNi, Al₂O₃, NiFe, Cu, Ni, Ti
- Analog output log-linear, 0 to 10 V DC
- Setpoints 1 relay, max. 60 V DC / 0.5 A (optional)
- Interfaces Profibus, DeviceNet (optional)
- Power supply 14.5 to 36 V DC, typ. 24 V DC / < 2 W
- Electrical connection FCC-68-plug, 8-pin with shield
- Weight 0.5 kg
- Protection category IP40
- Operating units MVC3

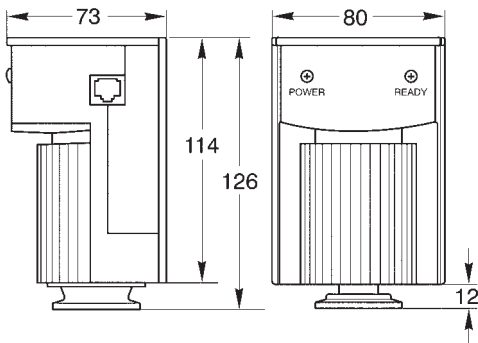

Order code	Sensor	Vacuum connection	Setpoint
LH-15734	PTR225	DN25KF	no
LH-16434	PTR225S	DN25KF	yes
LH-89641	PTR225PB (with Profibus)	DN25KF	no
LH-15736	PTR237	DN40CF	no
LH-89642	PTR237D (with DeviceNet)	DN40CF	no

IGM-401 hot cathode ionisation vacuum gauge module

Active Bayerd-Alpert gauge, for medium and high vacuum, with display, setpoint and serial interface

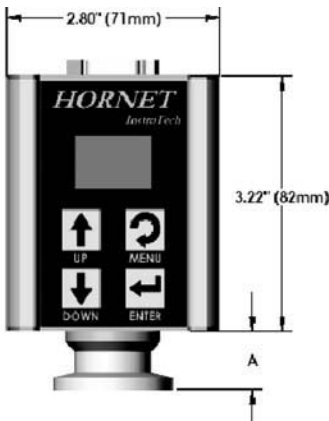

- Completely redesigned hot cathode ionisation gauge
- Rugged, compact metal design
- Dual cathode filaments
- Degas function by electron bombardment heating
- High measurement stability and reproducibility
- Replaceable gauge head
- Filament protection against overpressure by auto switch-off
- Bright OLED graphical display is invaluable during system fabrication and maintenance
- Log-linear analog output
- Compatible with GP Micro-Ion® modules

Technical data

- Measurement range: 6.7×10^{-2} to 1.3×10^{-9} mbar
- Measurement principle: hot cathode ionisation gauge according to Bayard-Alpert
- Sensitivity: factory set, user adjustable between 2 to 99 / Torr
- Display: OLED, graphical display, yellow 5-digit (3 x mantissa, 2 x exponent), plus further display elements
- Units: mbar, Pa, Torr
- Operating temperature: 0 to 40 °C
- Bake-out temperature: max. 200 °C (electronics removed)
- Materials in vacuum: tungsten, platin, molybdenum, stainless steel
- Filament material: yttria coated iridium
- Number of filaments: 2
- Mounting orientation: arbitrary
- Analog output: log-linear, 0 to 9 V DC (1 V / decade)
- Interface: RS-485
- Setpoint: 1 relay, max. 30 V / 1 A
- Power supply: 20 to 28 V DC / 14 W
- Electrical connection: 9-pin Sub-D-Plug
- Weight: 0.27 kg

Order code	Description	A (mm)
IGM401YCD	IGM-401 with DN25KF	37
IGM401YFD	IGM-401 with DN35CF	43
PS501-EU	Power supply 24 V DC, Input 90 - 240 V AC	43

ATMION® Compact wide range vacuum gauge

Active Bayard-Alpert/Pirani combination gauge for industrial vacuum and process control, for measurement from atmosphere to ultra high vacuum, with serial and optional ProfiBus interfaces

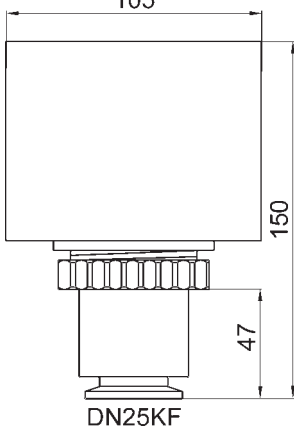
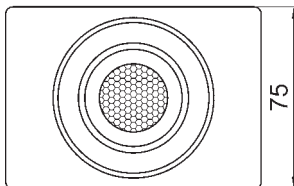
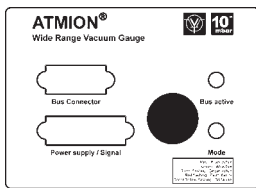

- Easy to integrate into programmable control systems
- Economic alternative to two single sensors
- Approved technology
- Safe, microprocessor controlled operation
- Long-living filaments due to intelligent control of emission currents
- Reliable process control due to high accuracy, stability and reproducibility, and short response times
- Simple and fast replacement of gauge head, easy recalibration
- Factory calibration
- Sensor degassing via electron bombardment heating
- Log-linear analog output
- Optional display of readings via PC, ATMIGRAF (page 8-29) or MVC3 (page 8-30)

Technical data

- Measurement range 1000 to 1×10^{-10} mbar
- Measurement principle hot cathode ionisation according to Bayard-Alpert / thermal conductivity according to Pirani (temperature compensated)
- Switch-over between sensors automatic
Pirani → BA at 1×10^{-2} mbar
BA → Pirani at 1×10^{-1} mbar
(adjustment of switch points is possible)
- Accuracy ± 25 % of reading at 10 to 1×10^{-2} mbar
 ± 10 % of reading at 1×10^{-2} to 1×10^{-8} mbar
- Operating temperature 10 to 40 °C
- Bake-out temperature max. 180 °C at flange (electronics removed)
- Materials in vacuum stainless steel, tungsten, glass ceramics
- Pirani filament material platinum
- BA filament material yttria coated iridium
- Number of BA filaments 2
- Mounting orientation arbitrary
- Analog output log-linear, 0 to 10 V DC (0.625 V / Dekade)
- Interfaces RS-232, optional Profibus
- Setpoints 1 transistor output, max. 24 VDC/ 0.2 A
- Power supply 24 V DC / 10 W, Degas max. 22 W
- Electrical connection 15-pin Sub-D plug
- Weight approx. 0.7 kg
- Protection category IP40
- Operating units ATMIGRAF, MVC3

Order code	Description
ATC25KLE	ATMION® Compact, DN25KF
ATC25KPLE	ATMION® Compact, DN25KF, Profibus
ATGC25K-HP	Replacement gauge head for ATMION® Compact, DN25KF
ATC35CLE	ATMION® compact, DN35CF
ATC35CPLE	ATMION® compact, DN35CF, Profibus
ATGC35C-HP	Replacement gauge head for ATMION® Compact, DN35CF
AT24E	Power supply 24 V DC, input 100 - 240 V AC
ATPC	Adapter for serial connection to PC
ATLPC3 / ATLPC5	Modem cable, 9-pin, 3 m / 5 m
USB-RS232-KONV	Serial USB/RS232 converter, Sub-D/USB adapter, 0.8 m USB cable, driver CD

ATMION® Standard wide range vacuum gauge

Active Bayard-Alpert/Pirani combination gauge optimised for R&D applications, for measurement from atmosphere to ultra high vacuum, with serial and optional ProfiBus interfaces

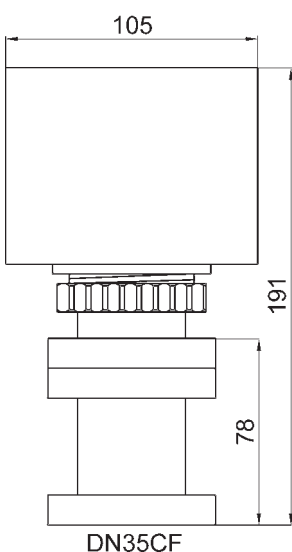
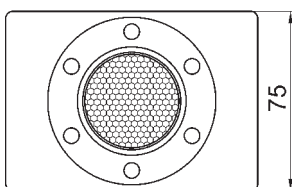
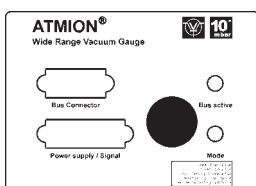

- High tolerable bake-out temperature
- Replaceable cathode filaments of the Bayard-Alpert sensor
- Economic alternative to two single gauges
- Approved technology
- Safe, microprocessor controlled operation
- Long-living filaments due to intelligent control of emission currents
- Reliable process control due to high accuracy, stability and reproducibility, and short response times
- Simple and fast replacement of gauge head, easy recalibration
- Factory calibration
- Sensor degassing via electron bombardment
- Well integratable into programmable control systems
- Log-linear analog output
- Optional display of readings via PC, ATMIGRAF (page 8-29) or MVC3 (page 8-30)

Technical data

- Measurement range 1000 to 1×10^{-10} mbar
- Measurement principle hot cathode ionisation according to Bayard-Alpert / thermal conductivity according to Pirani (temperature compensated)
- Switch-over between sensors automatic
Pirani → BA at 1×10^{-2} mbar
BA → Pirani at 1×10^{-1} mbar (Adjustment of setpoints is possible)
- Accuracy $\pm 25\%$ of reading at 10 to 1×10^{-2} mbar
 $\pm 10\%$ of reading at 1×10^{-2} to 1×10^{-8} mbar
- Operating temperature 10 to 40 °C
- Bake-out temperature max. 250 °C at flange (electronics removed)
- Materials in vacuum stainless steel, glass ceramics, tungsten
- Pirani filament material platinum
- BA filament materials yttria coated irridium
- Number of BA filaments 2
- Mounting orientation arbitrary
- Analog output log-linear, 0 to 10 V DC (0.625 V / Dekade)
- Interfaces RS-232, optional Profibus
- Setpoints 1 transistor output, max. 24 V DC / 0.2 A
- Power supply 24 V DC / 10 W, Degas max. 22 W
- Electrical connection 15-pin Sub-D-Plug
- Weight approx. 1.6 kg
- Protection category IP40
- Operating units ATMIGRAF, MVC3

Order code	Description
ATS35C	ATMION® Standard, DN35CF
ATS35CP	ATMION® Standard, DN35CF, ProfiBus
ATGS35C	Replacement gauge head for ATMION® Standard
ATF-001	Replacement filament pair for ATMION® Standard
AT24E	Power supply 24 V DC, input 100 - 240 V AC
ATPC	Adapter for serial PC connection
ATLPC3 / ATLPC5	Modem cable, 9-pin, 3 m / 5 m
USB-RS232-KONV	Serial USB/RS232 converter, Sub-D/USB adapter, 0.8 m USB cable, driver CD

THPS 760 PLUS vacuum controller

Display and control unit for an active piezo-resistive diaphragm gauge series HPM 760S

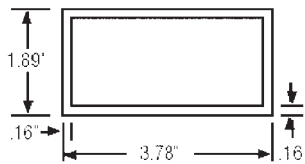

- High stability, accuracy and reliability, easy operation
- Power supply for the gauge via measurement cable
- Analog gauge signal is accessible at the rear side
- Two relays for mains voltage, setpoints adjustable with front buttons

Technical data

- Measurement channels 1
- Display range 1000 to 0.1 Torr
- Display LED, 4½-digit, red
- Units Torr
- Setpoints 2 relays, max. 240 V AC/ 2 A,
- Analog output linear, 0 to 10 V DC
- Operating temperature 0 to 50 °C (ambient)
- Power supply 85 to 240 V AC, 50/60 Hz
- Output voltage 24 V DC / 30 mA
- Housing plastics, 1/8 DIN, for panel mounting
- Weight 0.9 kg
- Scope of delivery display unit with 1.5 m power cable and 2.5 m gauge cable
- Connectable sensors HPM 760S with analog output 0 to 10 V DC

Order code	Description
THPS760Plus	Display unit for active piezo-resistive gauge series HPM 760S

DISPLAY ONE display and operating unit

for an active Pirani or a combined Pirani-capacitance gauge THERMOVAC TTR 90/91/100

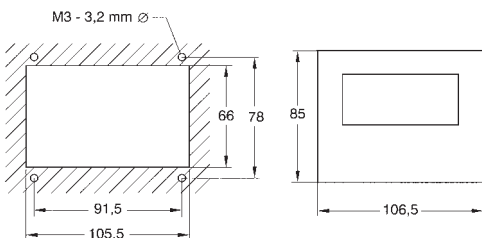

- Cost-effective, reliable, simple and compact
- Power supply for the gauge (24 V DC) via measurement cable
- Analog gauge signal is accessible at the rear side
- Setpoint of TTR91S is accessible at the rear side

Technical data

- Measurement channels 1
- Display range 1500 to 5 x 10⁻⁴ mbar
- Display LED, 4-digit (2 x mantissa, 2 x exponent) green
- Units mbar, Pa, Torr
- Setpoints 1 (with sensor TTR91S), 60 V / 0.5 A
- Analog output log-linear, 0 to 10 V DC
- Operating temperature 0 to 40 °C (ambient)
- Power supply 180 to 250 V AC or 90 to 130 V AC, 50/60 Hz / 5 VA
- Housing aluminium, 1/4 x 19", 2 RU
- Weight 1 kg
- Connectable sensors TTR91 (S), TTR100 (S)

Order code	Description
LH-235001	Display unit for Pirani gauge series TTR91/100, 115 V AC
LH-230001	Display unit for Pirani gauge series TTR91/100, 230 V AC
ATLP3	Sensor cable, 3 m*

* other cable lengths on request

ATMIGRAF display and operating unit

Display and operating unit for an active wide range vacuum gauge ATMION®

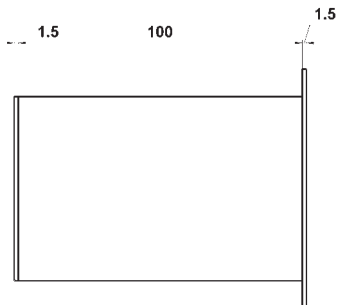
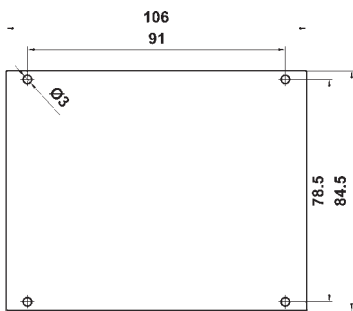

- Cost-effective, reliable, simple and compact
- Power supply for the gauge (24 V DC) via connection cable
- The following gauge outputs are accessible at the rear side of the unit:
 - Analog gauge signal
 - Transistor setpoint
 - Serial interface for gauge control

Technical data

- Measurement channels 1
- Display range 1000 to 1×10^{-10} mbar
- Display LED, 4 -digit (2 x mantissa, 2 x eponent), green mbar
- Units
- Setpoints 1 transistor setpoint (ATMION®), max. 24 V DC, 1.5 A
- Analog output log-linear, 0 to 10 V DC (0.625 V / decade)
- Interface RS-232 (9-pin Sub-D)
- Operating temperature 0 to 40°C
- Power supply wall power supply, in 90 - 250 V AC, out 24 V DC, EU plug
- Housing aluminium, 1/4 x 19", 2 RU
- Weight ATMIGRAF: 0.5 kg; wall power supply: 0.1 kg
- Scope of delivery ATMIGRAF, wall power supply
- Connectable sensors ATMION® Compact, ATMION® Standard

Order code	Description
AGPC-2	Display unit for ATMION® wide range gauge with wall power supply
ATL3 / ATL5	Sensor cable, 15-pin, 3 m / 5 m
ATLPC3 / ATLPC5	Modem cable, 9-pin, 3 m / 5 m
USB-RS232-KONV	Serial USB/RS232 converter, Sub-D/USB adapter, 0.8 m USB cable, driver CD

MVC3 multi-channel vacuum controller

Universal display and control unit for one to three active vacuum gauges

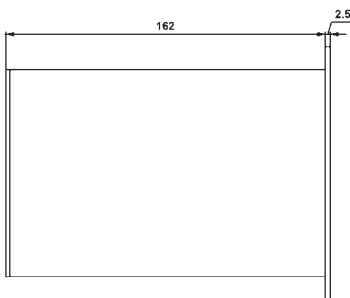
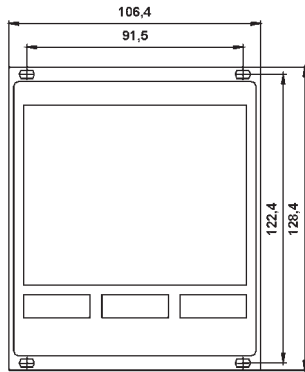

- For active capacitance, Pirani, convection Pirani, cold cathode and wide range Bayard-Alpert/Pirani vacuum gauges
- Flexible and accurate process control from atmosphere to 10^{-10} mbar
- Operates up to three gauges simultaneously
- Highly accurate signal processing
- Forward-looking, competitive and reliable technology in a space saving package
- Easy setup and operation:
 - Automatic identification of connected sensors
 - Power supply for all gauges via measurement cables
 - Comfortable, menu-guided operation via front keys
 - Clear, well readable display of readings, setpoint settings and various gauge functions
- Easy integration into (programmable) control systems:
 - Analog gauge signals accessible at the rear side
 - Up to 6 setpoint relays
 - Serial interfaces for controlling MVC3 and also wide range gauge ATMION® directly (if connected)

Technical data

- Measurement channels 1 to 3 (options see ordering table)
- Display range 1500 to 1×10^{-12} mbar (dependent on gauge)
- Display 1 to 3 lines; per line: (4 + 2)-digit LED; green
- Units mbar, Pa, Torr
- Measurement rate 50 /s
- Display rate 4 /s
- Accuracy amplifier error < 0.1 % F.S., offset error < 0.02 % F.S.
- Setpoints 2 relays per channel, max. 30 V / 1 A
- Analog outputs 1 per channel, 0 to 10 V, dependent on gauge
- Interfaces RS-232, RS-485 (9-pin Sub-D)
- Operating temperature 5 to 50 °C (ambient)
- Power supply 90 to 240 V AC / 50/60 Hz, max. 40 W
- Housing aluminium, 1/4 x 19", 3 RU, panel-mount or table top unit
- Weight 1.4 kg
- Connectable sensors CTR90/91/100, TTR90/91, TTR100, CVM-211, PTR225, ATMION®

Order code	Description
MVC3-AM	Display and control unit for one ATMION® and two other active gauges
MVC3-A0	Display and control unit for one ATMION® wide range gauge
MVC3-0M	Display and control unit for two active gauges except ATMION®
ATL3 / ATL5 / ATL10	Cable connecting MVC3 and ATMION®, 3/5/10 m
LSL3 / LSL5 / LSL10	Cable connecting MVC3 and TTR, PTR, 3/5/10 m
SSL3 / SSL5 / SSL10	Cable connecting MVC3 and CVM-211, 3/5/10 m
CSL3 / CSL5 / CSL10	Cable connecting MVC3 and CTR 3/5/10 m
USB-RS232-KONV	Serial USB/RS232 converter, Sub-D/USB adapter, 0.8 m USB cable, driver CD

MVC3-B UHV controller

Display and control unit for a passive UHV hot cathode ionisation gauge BAIS plus two optional active gauges for fore-vacuum control

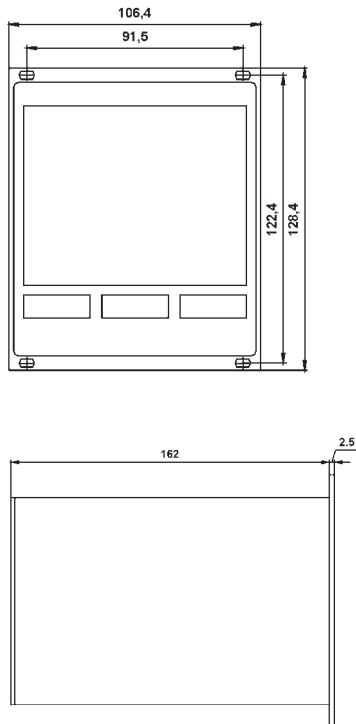

- Reliable UHV measurement to 10^{-11} mbar with passive UHV Bayard-Alpert gauge BAIS (page 8-32)
- Optional fore- and high vacuum measurement with active capacitance, Pirani, convection Pirani or cold cathode gauges
- UHV electrometer with high accuracy
- Forward-looking, competitive and reliable technology in a space saving package
- Easy setup and operation:
 - Automatic identification of connected sensors
 - Power supply for all gauges via measurement cables
 - Comfortable, menu-guided operation via front keys
 - Clear, well readable display of readings, setpoint settings and various gauge functions
- Easy integration into (programmable) control systems:
 - Analog gauge signals accessible at the rear side
 - Up to 6 setpoint relays
 - Serial interfaces

Technical data

- Measurement channels
 - 1 to 3
 - channel 1: BAIS (UHV electrometer)
 - channel 2/3 (optional): active gauges (see below)
- UHV electrometer range
 - 1×10^{-1} to 1×10^{-12} mbar
- Display range
 - 1500 to 1×10^{-12} mbar (dependent on gauge)
- Display
 - 1 to 3 lines; per line: (4 + 2) -digit LED; green
- Units
 - mbar, Pa, Torr
- Measurement rate
 - 50 /s
- Display rate
 - 4 /s
- Accuracy of UHV electrometer
 - 1 % of reading (without UHV gauge error)
- Accuracy of active sensor channels
 - 0.1 % F. S.
- Setpoints
 - 2 relays per channel, max. 30 V / 1 A
- Analog outputs
 - channel 1: log-linear 0 to 10 V DC
 - channel 2/3: dependent on gauges
- Interfaces
 - RS-232, RS-485 (9-pin Sub-D)
- Operating temperature
 - 5 to 50 °C (ambient)
- Power supply
 - 90 to 240 V AC / 50/60 Hz, max. 40 W
- Housing
 - aluminium, 1/4 x 19", 3 RU, panel-mount or table top unit
- Weight
 - 1.4 kg
- Connectable sensors
 - active: CTR90/91/100, TTR90/91, TTR100, CVM-211, PTR225; UHV (passive): BAIS (page 8-32)

Order code	Description
MVC3-B0	Display and control unit for one BAIS UHV ionisation gauge
MVC3-BM	Display and control unit for one BAIS UHV ionisation gauge and two active sensors
BAIS35C	Bayard-Alpert ionisation sensor, NW35CF
BAISL3 / BAISL5 / BAISL7	Cable connecting MVC3 and BAIS, 3/5/7 m
LSL3 / LSL5 / LSL10	Cable connecting MVC3 and TTR, PTR, 3/5/10 m
SSL3 / SSL5 / SSL10	Cable connecting MVC3 and CVM-211, 3/5/10 m
CSL3 / CSL5 / CSL10	Cable connecting MVC3 and CTR 3/5/10 m
USB-RS232-KONV	Serial USB/RS232 converter, Sub-D/USB adapter, 0.8 m USB cable, driver CD

BAIS UHV Bayard-Alpert ionisation gauge

Passive hot cathode ionisation gauge for high and ultra high vacuum, for use with MVC3-B UHV controller



- High accuracy, repeatability and measurement stability
- Short response time
- High-precision sensor assembly
- Long-living filaments due to MVC3-B's intelligent control of emission currents
- Replaceable cathode filaments
- Degas function by electron bombardment heating
- High tolerable bake-out temperature of gauge and measurement cable
- Robust stainless steel body
- Protective grid at vacuum port
- Factory calibration

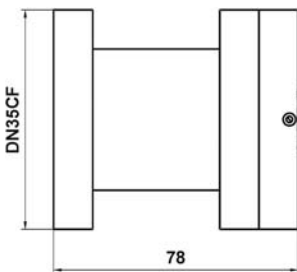

Technical data

- Measurement range: 10^{-2} to 10^{-11} mbar
- Measurement principle: hot cathode ionisation according to Bayard-Alpert
- Accuracy: $\pm 10\%$ of reading (range 10^{-2} to 10^{-8} mbar)
- Operating temperature: 10 to 40 °C
- Bake-out temperature: max. 400 °C, cable and plug removed; max. 250 °C with cable and plug
- Number of filaments: 2 (replaceable)
- Filament material: yttria coated iridium
- Materials in vacuum: stainless steel, glass ceramics, tungsten
- Operating units: MVC3-B



Order code	Description
BAIS35C	Bayard-Alpert-type UHV gauge, DN35CF
BAISL3 / BAISL5 / BAISL7	Cable connecting MVC3 and BAIS, 3/5/7 m

