 Vacuum solutions  
from a single source



## Vacuum solutions from a single source

Dear customers and prospective customers,

As Aristotle said, "The whole is more than the sum of its parts". This proverb is particularly true for the vacuum industry, where performance, precision and reliability are vital. The various components and parts in a system need to be precisely coordinated with one another and harmonize perfectly to ensure that the vacuum solution shows the expected quality during operation.

The immense growth over the past two years and the integration of new companies into the Group has allowed Pfeiffer Vacuum to enormously expand its product portfolio and offer even more Vacuum solutions from a single source: from individual components to complex systems. We are the only supplier of vacuum technologies with a complete product range for every application, every industry and every customer requirement. This gives you, as our customer or prospective customer, the opportunity to acquire all the components for your vacuum solutions from a single source. A huge advantage when it comes to your application's quality and performance. We place very high demands on our products and act as your competent partner, providing you with the perfect solution.

The following catalog illustrates our competence and product variety and helps you better understand the theory and practice associated with vacuums.



A look at the sheer size of the second edition of our "Vacuum Technology Book" visualizes the extent of our product range. However, Pfeiffer Vacuum solutions are not only characterized by the enormous engineering skills applied in our products; we rely on the concept of a complete program and offer service solutions and consulting at the highest level. Therefore, the following five sections will not only provide you with an extensive overview of our products but also give you detailed insight into the world of vacuum solutions offered at Pfeiffer Vacuum. In the first section of the catalog, you will find numerous possibilities for cooperation, continuing education and detailed information.

The second section provides essential basics and background knowledge of vacuum technology, constituting the necessary basis for working successfully with vacuums. Thanks to years of proven scientific development and practical applications, this expertise section was completely revamped and now contains state of the art information and concepts.

Parts 3.1 to 3.3 present our new product ranges for vacuum generation, measuring, analysis, leak detection, chambers and components. With information about individual product lines, selection tables, decision making tools, simple order information as well as an extensive index, we offer you a vast range of information to help you select your vacuum solution.

We hope that this broad collection of trail blazing vacuum technology information will be helpful for your vacuum requirements and we look forward to working with you.

Your Pfeiffer Vacuum team

 A passion for perfection

# Content

<b>Vacuum solutions from a single source</b>	
<b>1. Pfeiffer Vacuum history at a glance</b>	<b>6</b>
<b>2. Complete solutions for every vacuum range</b>	<b>8</b>
<b>3. Vacuum solutions: leak detection system</b>	<b>10</b>
<b>4. The markets of Pfeiffer Vacuum</b>	<b>12</b>
Analytics .....	14
Industry .....	18
Research & development .....	22
Semiconductor .....	26
Coating .....	30
<b>5. Product safety at Pfeiffer Vacuum</b>	<b>34</b>
<b>6. Pfeiffer Vacuum product range</b>	<b>36</b>
Vacuum generation .....	36
Vacuum measurement .....	52
Analysis .....	54
Leak detection .....	58
Systems .....	62
Vacuum components .....	64
<b>7. Vacuum as a basis for our modern life</b>	<b>72</b>
<b>8. Energy efficiency as our company philosophy</b>	<b>74</b>
<b>9. Pfeiffer Vacuum consulting</b>	<b>78</b>
eVacuum app and internet .....	80
<b>10. Pfeiffer Vacuum service solutions</b>	<b>82</b>
Range of services .....	84
<b>11. On-site worldwide for you</b>	<b>86</b>

# 1. Pfeiffer Vacuum history at a glance

## Vacuum technology since 1890



**1890** Arthur Pfeiffer founds company in Wetzlar (Hesse) in Germany



**1904** Arthur Pfeiffer acquires the license for the manufacture and sale of the Guericke oil air pump

**1929** Arthur Pfeiffer – development of exhibits for a show in Leningrad. More than fifty different pumps for the chemical and pharmaceutical industry presented by the Pfeiffer company.



**1958** Willi Becker – invention of the molecular turbopump

**1974** Delivery of the first turbopump for use in an electron microscope



**1985** Invention of the SplitFlow™ turbopump

**1978** Delivery of a TPU 25 type turbopump to NASA



Launch of the ASM 110 helium leak detector with integrated turbopump



**2000** DigiLine – first complete digital series of vacuum gauges launched

1900                      1920                      1940                      1960                      1980                      2000

**1910** Arthur Pfeiffer develops the rotating oil air pump



**1934** Arthur Pfeiffer – exhibition in Paris



**1955** Willi Becker develops a concept for multi-stage molecular turbopumps



**1975** Launch of the ASM 10 helium leak detector



**1973** Single-stage rotary vane pump UNO 1.5 A











**1999** First turbopump with integrated electronic drive unit







**1996** Launch of rotary vane pumps with magnetic coupling



**1966** Launch of the first helium leak detector ASM 4



<p><b>2003</b> HiPace® 2400 MC – the world’s first magnetically levitated turbopump with integrated electronic drive unit</p>  <p>Turbopumps TMU 071 on board of the International Space Station (ISS)</p> 	<p><b>2005</b> OnTool Booster – new high vacuum pump against atmosphere</p>  <p>The new leak detector SmartTest wins the Red Dot Design Award</p> 	<p><b>2008</b> HiPace® 10–2,000 l/s – new giant in vacuum technology</p> 	<p><b>2010</b> Pfeiffer Vacuum acquires Trinos Vacuum System GmbH</p> <p>New: HiPace® M – compact magnetically levitated turbopump</p> <p>Pfeiffer Vacuum acquires the “adixen” vacuum technology division from Alcatel Lucent</p> 	<p><b>2013</b> New: ASM 340 leak detector, new series of the rotary vane pump DuoLine™</p>  
--	--	--	--	--

<p><b>2002</b></p> <p><b>2004</b> Pfeiffer Vacuum XtraDry – oil-free backing pump</p>  <p>New series of compact high performance turbopumps</p> 	<p><b>2007</b> Launch of PentaLine® – new two-phase rotary vane pump</p> 	<p><b>2009</b> New: HiCube® – modular pumping station for clean vacuum</p> <p>OmniStar / ThermoStar – the new gas analysis system</p> <p>First portable leak detector ASM 310</p>  	<p><b>2012</b> Launch of the MiniTest – portable helium leak detector for industrial use</p> 
--	--	--	--

## 2. Complete solutions for every vacuum range

**Pfeiffer Vacuum offers extensive solutions from a single source. A strong partner with a broad complete program.**

From consulting in the initial offer phase to the servicing of installed systems, Pfeiffer Vacuum stands for top quality products and services. Unique to Pfeiffer Vacuum is the **combination of extensive technical expertise, high value products, competent advice and customer friendly service.**

- **Whether for vacuum generation, measurement, analysis, leak detection, complete systems or components:** the Pfeiffer Vacuum product portfolio offers the perfect solution to meet every need. Excellent quality and state-of-the-art technology are standards with all products.
- To best meet your requirements, we offer a **broad range of consulting services.** We work closely with you right from the planning stage to best meet your needs. In addition, we also offer information in the form of a full catalog, a vacuum technology compendium, in the Internet and in a mobile app. Pfeiffer Vacuum describes the scientific principles of vacuum technology, offers technical details and provides vacuum expertise – perfect for both practice and research.
- The complete range also includes **extensive services:** Our product training and other courses provide the technical basics of vacuum technology along with important information about the proper operation of our products in the real world.

Thanks to our service offices and our competent customer service, we can be on site quickly – anywhere, anytime. With repairs, support for independent maintenance, product servicing and maintenance, we will help you – and only use original replacement parts.

**Vacuum solutions from a single source – professional, customer friendly and competent.**



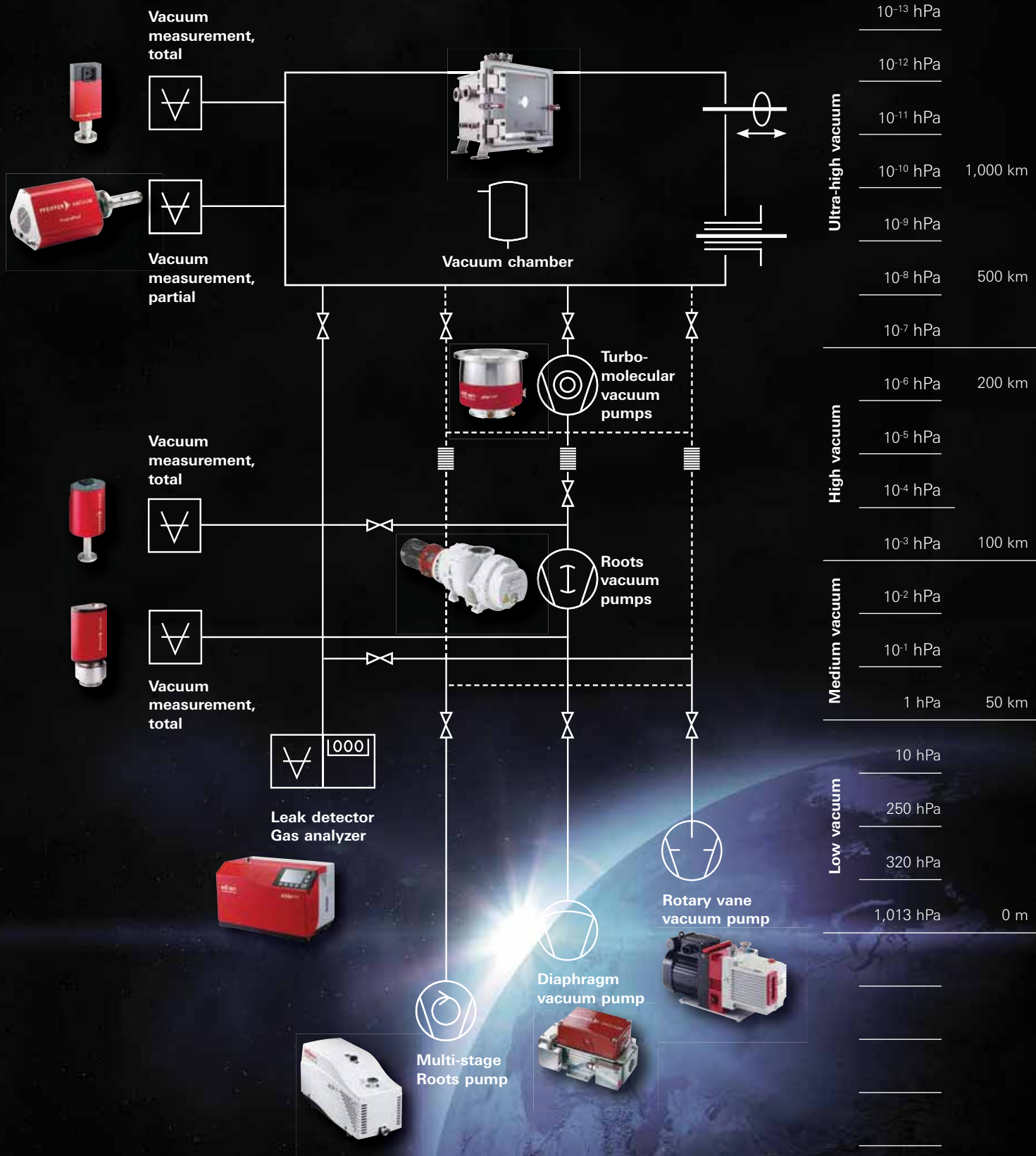

Example of a vacuum solution from Pfeiffer Vacuum's product portfolio with an overview from low vacuum to ultra-high vacuum

### 3. Vacuum solution using the example of a leak detection system

#### The whole is more than the sum of its parts

A solution is just as unique as its application – which is why we focus on our customers' needs by offering consultation for individual products, service or complete system solutions.

Individual components are precisely adapted and combined with one another. The focus is always on the customer's specific requirements and expectations. See for yourself what our product range holds and discover the possibilities for designing a leak testing system using our extensive product range!



Leak testing system as a vacuum solution with Pfeiffer Vacuum components

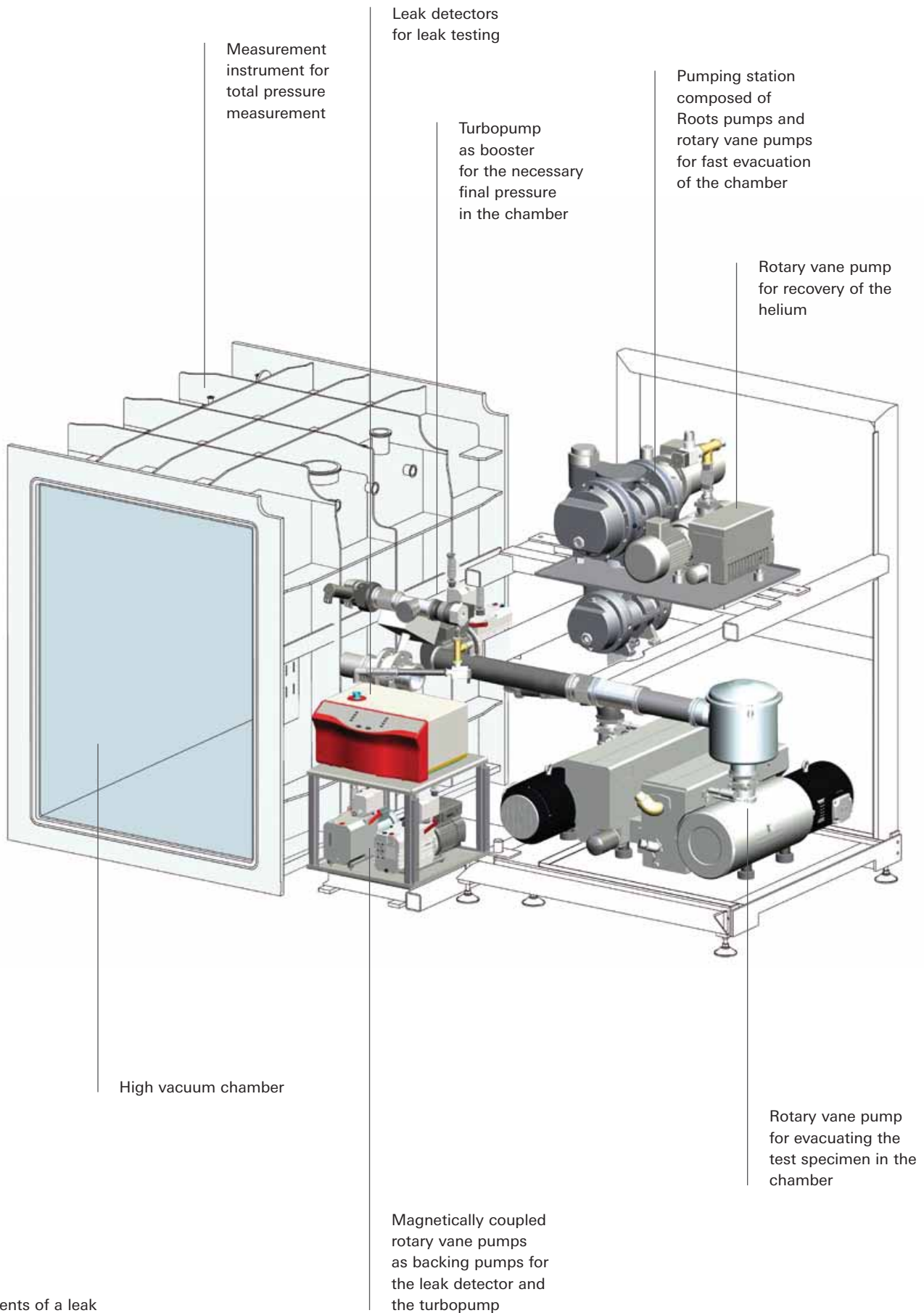

Components of a leak testing system from a single source

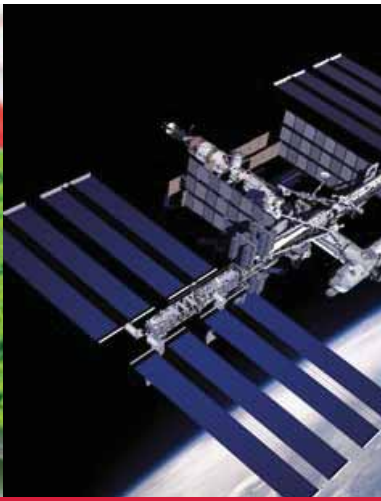

## 4. The markets of Pfeiffer Vacuum

Vacuum solutions for many applications and numerous market segments

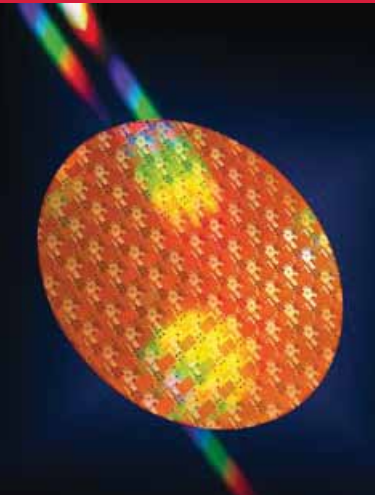

## Technology needs vacuum. We provide extensive solutions for these markets:



**Analytical industry** for the manufacture of complex scanning electron microscopes used in pharmaceutical quality assurance or mobile systems for doping checks in sport. (Pages 14–17)



**Industrial applications** such as freeze-dried food products, light bulb and pipe manufacture or leak detection for the quality assurance in the automotive industry. (Pages 18–21)



**Research & development**, wherever new technologies and applications arise that can then be marketed. For example, ion accelerators and irradiation equipment for precise tumor therapy have recently been launched. (Pages 22–25)

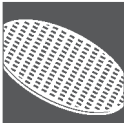

**Semiconductor industry** for the manufacture of wafers as the basis for microchips, flat screen monitors, handling systems as well as organic LEDs. (Pages 26–29)

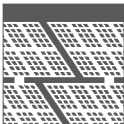

**Vacuum coating** of tool surfaces, architectural glass, solar cells, bathroom fixtures, DVDs or anti-reflection coating of eyeglass lenses. (Pages 30–33)



## 4. The markets of Pfeiffer Vacuum

Application example: Analytics

## Better understanding of the pyrolysis of PVC



Thermogravimetric analysis (TGA) is an analytical method used to measure the change in mass of a sample based on temperature and time. The objective is generally to determine the composition of rubber or plastic as well as other materials used in the chemical and pharmaceutical industries. Instruments using thermogravimetric analysis may be coupled with analyzers such as mass spectrometers to facilitate the interpretation by determining the mass-to-charge ratio. This is known as evolved gas analysis (EGA). The following application – the pyrolysis of polyvinyl chloride (PVC) – will illustrate the procedure.

### Analysis of PVC combustion processes

Polyvinyl chloride (PVC) is a thermoplastic material, which is primarily characterized by its high weather resistance. This characteristic, which is very positive for the use of the material, means that it can often only be disposed by incineration. Thermogravimetric analysis combined with the EGA can help to better understand the combustion process.

### The solution made by Pfeiffer Vacuum

To illustrate the combustion process, thermo-balances from Mettler Toledo have been connected to the ThermoStar gas analyzer with an integrated mass spectrometer from Pfeiffer Vacuum. ThermoStar, a special solution for the coupling with thermo-balances, can be used to investigate what happens to powdered PVC when heated and to analyze the composition of the vaporizing material. ThermoStar has a quartz capillary that can be heated in an insulated tube to 200 °C (optionally 350 °C). This prevents vapors from condensing during the process analysis. It allows the supervision of 128 different masses. The analyzer can also be used to reliably identify unknown gases with the help of spectral libraries.

ThermoStar consists of a heated and temperature-regulated gas inlet system with quartz capillaries and a platinum orifice, the PrismaPlus quadrupole mass spectrometer, an MVP 020-3 dry diaphragm vacuum pump and a HiPace turbopump. The analyzer is suitable for qualitative and quantitative gas analyses and covers the mass ranges of 1 to 100 amu, 1 to 200 amu or 1 to 300 amu. The capillary inlet allows for an almost completely non-segregated gas transfer. The compact and convenient analytical unit can be directly connected to the thermo-balance and is then ready for immediate use.



Coupling of a Mettler Toledo TGA/DSC 1 with a Pfeiffer Vacuum ThermoStar GSD 320

# 4. The markets of Pfeiffer Vacuum

## Applications and products for analytics

In analytical laboratory technology, measurements and studies under both cleanroom conditions and enclosed vacuum conditions are always highly valued. Vacuum analytics, in particular, produces significantly higher quality results and is one of the acknowledged measuring and analytical methods in modern lab technology.

### Requirements for optimal vacuum pumps in a lab:

- Compact design
- Low noise operation
- High pressure stability
- Relevant and reproducible analytical procedures including high vacuum and ultra-high vacuum
- Availability in various technical versions depending on the specific requirements

### In addition to vacuum pumps for laboratories, Pfeiffer Vacuum also provides the technological environment for modern applications from backing vacuum pumps and turbopumps to measurement instruments and leak testing in high vacuum:

- Complete pumping stations are also available in customized versions
- Various accessories for the smooth and clean functioning of the vacuum solution
- Extensive services
- From low vacuum to ultra-high vacuum



### Analytics

#### Applications

##### Mass spectrometry

Spectroscopy, medical technology, pharmaceuticals, e.g. for modern analytical procedures for separating molecules

##### Leak detection

Refrigeration/air-conditioning technology, fully automated leak detection

Helium leak detection, leak detection in fuel tanks or fiberglass sleeves

Selective detection of gas types

##### Gas analysis

Process gas monitoring, respiratory gas analysis, thermogravimetric analysis, residual gas analysis, ion analysis, plasma diagnosis, exhaust inspection, e.g. for quantitative or qualitative determination of gas composition in environmental and biotechnology

##### Electron microscopy



















Electron microscopes, all areas of application, e.g. measurement procedures for qualitative evaluation of material and surface structures

##### Surface analysis

Quality assurance in measuring procedures for the qualitative evaluation of material and surface structures



Product range for analytical applications

Rotary vane pumps	Diaphragm vacuum pumps	Screw pumps	Side channel pumps	Multi-stage Roots pumps	Roots pumps	Roots pumping stations	Turbopumps	Turbo pumping stations	Measurement equipment	Analysis equipment	Leak detectors	Systems	Chambers	Components	Valves	Feedthroughs	Manipulators
																	
■	■		■	■			■		■	■	■		■	■	■	■	■
■	■			■	■		■		■	■	■		■	■	■		
■	■			■	■		■		■	■	■		■	■	■		
■	■			■	■		■		■	■	■		■	■	■	■	■
	■			■			■		■	■	■		■	■	■		
	■			■			■		■				■	■	■		



## 4. The markets of Pfeiffer Vacuum

**Application example: Industry**



## The sun as a natural power plant



High temperature solar thermal systems represent an interesting alternative to photovoltaic power generation: Solar thermal plants use concentrating collector systems which guide solar radiation bundled to an absorber tube. These systems are installed in regions with high direct solar radiation such as Spain, California or North Africa and transmitted via high voltage direct current lines even to distant consumers.

The renowned DESERTEC project, where electricity is generated in deserts by the aid of solar thermal power plants, has raised the opportunity of this technology.

### The technology

In a solar thermal parabolic trough power plant, trough-like mirrors reflect sunlight onto an absorber, the receiver. It is filled with a heat transmitting fluid, which is brought to a steam turbine in the power plant section of the system. Additional heat tanks in the power plant balance out short term fluctuations in solar radiation.

### Why vacuum?

Vacuum is absolutely vital for the efficiency of the power plant, to make sure that the heat generated is not lost, and to evacuate the receivers. The receiver consists of a glass cladding tube and an inner steel tube. The radiation transfer steel tube needs to be isolated, without limiting the solar heat. Vacuum insulation and the use of special glass for high transmission of sunlight as well as special coatings significantly reduce radiation and convection losses. In the receiver production, various Pfeiffer Vacuum solutions are used, such as our specifically adapted turbo pumping stations for the evacuation of the receiver tubes.

### What pressure is needed?

To generate an insulating effect, heat transmission through convection must be eliminated. This is achieved by pumping out air, which acts as the heat transfer medium. Heat loss will then only occur through radiation, which transports far less energy than convection. This effect is generated at pressures below  $10^{-3}$  hPa. The specified pressure needs to be maintained over the life of the receiver. In addition, gas intake due to permeation through sealing materials, desorption by the walls or leaks must be minimized. The leak tightness requirement is tested in a helium leak detection system. When designing an industrial leak detection system for a solar thermal power plant, full automation ensures high process consistency and reliability. Pfeiffer Vacuum will support you with advice and systems planning and also offers customized solutions for complete vacuum technology in the individual production phases.

# 4. The markets of Pfeiffer Vacuum

## Applications and products for industry

The quality demands in the manufacture of industrial products are constantly rising. This makes vacuum technology ever more important. Pfeiffer Vacuum products are excellent for the implementation of efficiency and environmental standards. Emission reductions, such as those in the automobile industry, can be carried out economically thanks to vacuum technology. Pfeiffer Vacuum offers you a complete product range tailored to meet industrial needs.



### Industry

#### Applications

##### Materials

Melting and crystal extrusion, e.g. single silicon crystals

Steel degassing of special steel smelting

Heat treatment, sintering, nitriding or soldering in vacuum furnaces

Electron steel welding and smelting of wind turbine blades or vehicle transmissions, molds for prototype components.

Conditioning and casting of power isolators

##### Mobility

Quality assurance using leak detection in air conditioning components, vehicle tanks, injection systems, etc.

Evacuation and ventilation of brake systems

##### Air conditioning and refrigeration

Quality assurance using leak detection in air conditioning components, cooling systems and cooling equipment, compressors, valves

Conditioning of isolation vacuum for low temperature equipment and cryostats

Evacuation and filling of refrigerants in cooling machines

##### Power

Evacuation, drying and waterproofing of high power performance

Conditioning and quality assurance of solar receiver tubes

Evacuation and conditioning of kinetic power storage

Coating and testing of fuel cells and modules

Degassing, drying and impregnating of deep-sea cables

##### Chemical and technical gases

Distillation and degassing of monomers to produce granulates, production of base materials

Solvents and basic material production

Conditioning and testing of gas cylinders

##### Medicine

Evacuation and qualifying of protons and heavy ion accelerators for cancer therapy

Plasma sterilization and drying medical instruments

Freeze drying e.g. of pills

Industrial product range

Rotary vane pumps	Diaphragm vacuum pumps	Screw pumps	Side channel pumps	Multi-stage Roots pumps	Roots pumps	Roots pumping stations	Turbopumps	Turbo pumping stations	Measurement equipment	Analysis equipment	Leak detectors	Systems	Chambers	Components	Valves	Feedthroughs	Manipulators
■		■			■	■			■		■		■	■	■	■	■
		■			■	■			■				■	■	■		
■		■		■	■	■	■		■		■		■	■	■		
■				■	■				■			■		■	■	■	■
■					■		■		■		■		■	■	■		■
■					■				■			■	■	■	■		
■					■	■	■		■		■		■	■	■		
■				■	■	■	■	■	■			■	■	■	■	■	■
■	■				■		■	■	■		■	■		■	■	■	■
■				■	■		■		■	■	■			■	■	■	
■		■			■	■			■				■	■	■	■	■
■				■	■	■			■		■	■		■	■	■	■
■					■		■	■	■	■	■		■	■	■	■	■
■				■	■	■			■		■	■		■	■	■	■
■	■				■	■			■	■			■	■	■	■	■



## 4. The markets of Pfeiffer Vacuum

Application example: Research & development



The VLT (Very Large Telescope) in action. Source: ESO/S. Brunier

## Vacuum technology allows deepest glimpses into the universe



ESO, the “European Organization for Astronomical Research in the Southern Hemisphere”, operates astronomical observatories world-wide. In many telescopes, Pfeiffer Vacuum turbopumps have been reliably providing a clean vacuum in signal detection for the operation of infrared instruments for more than ten years. The ESO is now testing an ATH 500 turbopump intended for the use in the VLT (Very Large Telescope) and the E-ELT (European Extremely Large Telescope), which will begin operations in 2018.

### High requirements for vacuum in signal detection

On the one hand, vacuum in earthbound large telescopes is needed for coating reflective surfaces. On the other hand, it is mainly important for the analytical devices in signal detection. Infrared instruments composed of a CCD detector field and operated at low temperatures between 4 and 60 kelvin are just one example. The instruments are evacuated under high vacuum conditions before being cooled. The entire process presents enormous challenges to vacuum technology. It is then necessary to use pumps that are entirely oil-free. Back diffusion from hydrocarbons could otherwise cause condensation on the instruments severely compromising the telescope’s performance. Even during operation, the pump system needs to cope with the rapid angular velocity of the telescope, run smoothly and generate almost no vibrations. A constant temperature range of  $+1/-3^{\circ}\text{C}$  is also important as every degree of temperature generates mild convection, which may disrupt visual observations.

Stable operations and reliability are of the utmost importance as the telescopes are often located on mountaintops in tectonically active regions.

### The vacuum solution from Pfeiffer Vacuum

The ATH 500 turbopump is assessed under these conditions and examined in a test stand, which is a copy of the instrument holder for the observatories in Chile. The test procedure allows for detailed simulations of vibrations and radial acceleration. The vibration spectrum in the ATH 500 has only a few higher frequencies. The highest angular acceleration was  $1 \text{ deg/s}^2$ , which is double the value set for astronomic practice. The pump went through ten tests under the most difficult conditions with no disruptions. The compact design with integrated electronics and low surface temperatures complies precisely with the application requirements.



# 4. The markets of Pfeiffer Vacuum

## Applications and products for research & development

### Vacuum solutions for research & development

Innovative and exciting new technical products enrich and simplify everyday life. To get there, intensive research and development is needed. Essential accomplishments would not have been possible without the help of vacuum.

Pfeiffer Vacuum products are used in numerous areas of research such as:

- Research labs at universities, large research centers and industrial research facilities in Europe, the US, Asia and other parts of the world
- Renewable energy research

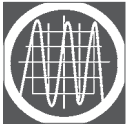

### Research & development

### Applications

#### Renewable energy

- Fusion reactors
  - For the generation of an isolating vacuum in fusion reactors
  - For the generation of a vacuum in the tokamak's torus
  - For the evacuation of neutral beam injectors to heat up plasma
  - For the generation and measurement of vacuum in stellarators of fusion reactors
  - For the generation of plasma and for heating plasma

Examination of new, highly efficient photovoltaic cells

Analysis of new materials for batteries

Analysis of helium/deuterium

Leak detection in large vacuum containers

#### Accelerators

In accelerators for the preconditioning and generation of the isolating vacuum

Measurement and analysis of vacuums in accelerators

Evacuation of beam lines for conducting experiments

#### Basic research

Vacuum generation and designing experiments in vacuums

Laboratory coating systems for the development of semiconductors

Development of surface analyses in vacuums

Mass spectrometer analyses in materials research



















Respiratory gas analysis for pilots and astronauts

Design and development of space simulation experiments

Development and testing of analytical equipment in space



Research & development products

Rotary vane pumps	Diaphragm vacuum pumps	Screw pumps	Side channel pumps	Multi-stage Roots pumps	Roots pumps	Roots pumping stations	Turbopumps	Turbo pumping stations	Measurement equipment	Analysis equipment	Leak detectors	Systems	Chambers	Components	Valves	Feedthroughs	Manipulators
																	
■	■	■	■	■	■	■	■	■	■	■	■	■		■	■	■	■
■	■	■	■	■	■		■	■	■	■	■		■	■	■	■	■
■	■	■	■	■	■		■	■	■	■	■		■	■	■	■	■
■	■	■	■	■	■		■	■	■	■	■		■	■	■	■	■
■	■	■	■	■	■		■	■	■	■	■		■	■	■	■	■
■			■	■			■	■									
■	■	■	■	■	■	■	■	■	■	■	■	■	■	■	■	■	■
			■	■			■	■	■	■	■	■		■	■	■	■
■	■		■	■	■		■	■	■	■	■	■	■	■	■	■	■
■	■	■	■	■	■		■	■	■	■	■	■	■	■	■	■	■
■	■	■	■	■	■	■	■	■	■	■	■	■	■	■	■	■	■
■		■	■	■	■	■	■	■	■	■	■		■	■	■	■	■
■		■	■	■	■	■	■	■	■	■	■		■	■	■	■	■

## 4. The markets of Pfeiffer Vacuum

Application example: Semiconductor industry

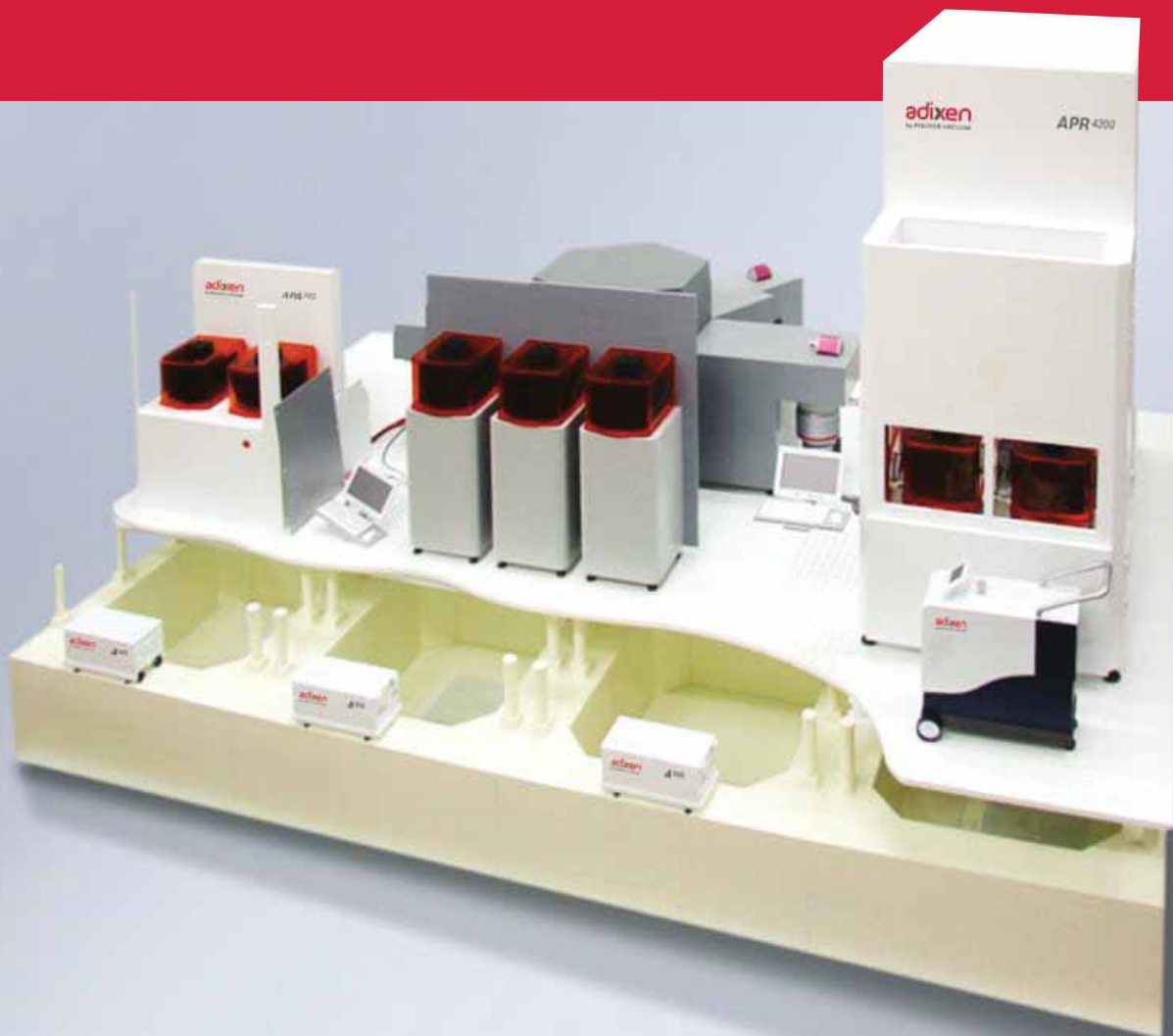



## Strong partner for the semiconductor industry



Many achievements of modern life are based upon semiconductor technology. Without it, trailblazing inventions such as the transistor, of which millions are located on a single high performance chip, would not have been possible. These semi-chips are used in computers, mobile telephones, digital cameras, MP3 and DVD players, flat-screen monitors, modern memory storage (flash memory), automobiles as well as household appliances. Many of these products can only be produced in a very clean vacuum environment. With its broad product portfolio, Pfeiffer Vacuum offers entire solutions for semiconductor technology such as complete systems for semiconductor fabrication plants, known as "fabs". Using a specially developed model of such a fab, Pfeiffer Vacuum can clearly illustrate the impressive opportunities created by equipping such a plant from a single source.

### Complete solutions for a semiconductor fab by Pfeiffer Vacuum

The model consists of four levels. The upper clean room includes production plants as well as special systems such as the APA 302 and APR 4300. They ensure high quality contamination management. ASM 380 leak detectors support the employees in maintenance and quality assurance. In addition, turbopumps as well as vacuum measuring equipment from the DigiLine series are installed along with a PrismaPlus mass spectrometer. In this area, only the most indispensable activities are allowed – solely in cleanroom clothing. The integrated A 100 L ES pump evacuates the load-locks or transfer chambers. It is either located close to the chamber, integrated in the systems or in the sub floor – an intermediate area below the floor of the clean room.

The cooling equipment, power supply and RF generators for the system are installed one floor below. The lower floor contains the dry pumps as well as abatement.

### Pfeiffer Vacuum products used in numerous applications

All of the process phases in the production of a wafer take place in a fab: Lithography, inspection, coating and engraving processes as well as implantation. The manufacture of the wafer itself as well as the components and the packaging take place in special production areas.

Vacuum solutions from Pfeiffer Vacuum are used in a wide variety of such fabs and allow the equipment of all semiconductor applications with high quality and individually designed products from a single source.

# 4. The markets of Pfeiffer Vacuum

## Applications and products for the semiconductor industry

Without vacuum technology, trailblazing inventions such as the transistor, of which there are millions on a high performance chip, could not have been developed and manufactured. These semiconductor chips are used in computers, mobile telephones, digital cameras, MP3 and DVD players, flat-screen televisions, modern memory storage (flash memory), automobiles as well as household appliances.

Pfeiffer Vacuum offers turbopumps, backing pumps, pumping stations, leak detectors and measuring devices for the following applications:

- Coating
- CVD-processes
- Lithography
- Engraving and implantation processes
- Transfer in process chambers
- Wafer transport
- Electron microscopes (SEM and SLM)



### Semiconductor

#### Applications

<b>Chemical vapor deposition (CVD)</b>	Manufacture of non-conducting or isolating layers in semiconductor production using PE-CVD, LP-CVD, HDP-CVD, Atomic Layer CVD
<b>Physical vapor deposition (PVD)</b>	Manufacture of conducting layers, e.g. using sputtering, load-locks
<b>Lithography</b>	Application of structures on wafers, such as photo lithography, x-ray lithography, electron beam lithography, EUV lithography, load-locks
<b>Etching</b>	Etching out of layers after lithography for the generation of structures, e.g. using dry etching, plasma etching, reactive ion etching.
<b>Ion implantation</b>	To alter conductivity of materials such as silicon, foreign atoms are inserted into the structure. Uses of our products include source, beam line, analytical magnets
<b>Inspection &amp; metrology</b>	Testing and verification of structures, which are applied using lithography, e.g. scanning electron microscopes (SEM), laser scanning microscopes (LSM)
<b>Load-locks and transfer chambers</b>	Loading of wafers in process chambers
<b>Bonds</b>	The creation of contacts to and between wafers, particularly to support MEMS productions, for the manufacture of CMOS image sensors, for advanced packaging and for 3D interconnects Areas of use: Wafer bonds and temporary bonds
<b>Contamination Management/ AMC Solutions (Airborne Molecular Contamination)</b>	Analysis or regeneration of FOUPs and wafers after various semiconductor production processes, e.g. after etching





## 4. The markets of Pfeiffer Vacuum

**Applications and products for the coating industry**

## Broad product range for the needs of the glass coating industry

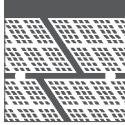

The growing global importance of energy efficiency and environmental awareness causes an increasing demand for low emission coatings. The coating technology is used in architectural and automobile glass as well as thin-film solar cells. The Asian markets especially have experienced strong growth, particularly in the architectural sector. China, for example, is solely responsible for 40% of the overall demand for coated glass. Coating systems are generally used 365 days a year, usually for 15 years and more. These long uptimes set tough demands. In addition to robustness, high reliability and longer life, lowest possible operating costs are becoming more and more important. As a proven partner for the coating industry, Pfeiffer Vacuum designs tailored complete solutions that meet all the requirements placed on an inline sputter coating system.



Systems for glass coating with HiPace turbopumps from Pfeiffer Vacuum for Leybold Optics GmbH

### Perfect solutions thanks to individual planning

With the help of vacuum pump simulations, Pfeiffer Vacuum is able to support its customers already in the design phase with suggestions for cost savings through improved conductance. In the implementation phase, the magnetic bearing technology in the pumps combines highest possible performance with minimal power consumption (generally 0.2 kW at the highest loads) and low use of cooling water (60 l/h clarified water). Careful maintenance ensures maximum operating periods for a coating system, which is continually optimized in cooperation with the customer. When it comes to glass coating, we focus on launching new processes (such as HDMSO) and the byproducts that can be generated in a process.

### Central monitoring system for comfortable system control

A central monitoring system allows all the pumps (up to 200) in an inline sputter system to be monitored. The system provides access to the key data such as rotation speed, energy consumption and temperature. Error displays allow for quick reactions.

### After sales service for best product functionality

Pfeiffer Vacuum has established a sales and service network for long product life and lowest possible down times. It guarantees fast and reliable service around the world, seven days a week. A wide range of training courses provides background knowledge and technical information on the operation and maintenance of the installed vacuum system as well as background training courses about customer specific subjects round off Pfeiffer Vacuum's services.

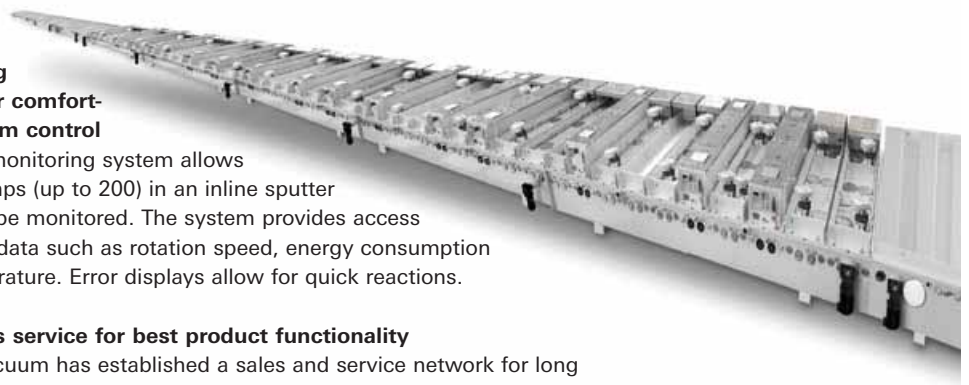

# 4. The markets of Pfeiffer Vacuum

## Applications and products for the coating industry

Vacuum technology has revolutionized the production of machines, tools, consumer goods and electronic devices. The thin-film procedures in high vacuums allow the coating of various materials in thin layers of ultra-high metallic coatings. The 2 to 5 micrometer thin layers of aluminum, gold, silver, copper or zinc provide more than decorative effects. They create wear-free corrosion protection. If the layers get extremely thin at 10 to 100 nanometers, the system moves into the area of nanotechnology. In this range, the extremely thin coating produced in a vacuum can improve the material characteristics such as hardness or friction properties compared to those of uncoated materials.



Coating

### Applications

















<b>Hard coating</b>	Wear protection layers: – Tools, motor blocks
<b>Cold mirror reflectors</b>	Plastic and glass surface coating: – Halogen lamps, car headlights
<b>Reflective diffusion barrier layers</b>	Plastic surface coating: – PET bottles, fuel tanks, clear packaging
<b>Reflective surface processing</b>	Decorative layers – Jewelry, perfume bottles, bathroom and kitchen fixtures
<b>Ophthalmics</b>	Optical layers for non-reflective surfaces, coloring or scratch protection: – Eyeglass lenses, camera lenses
<b>Storage media</b>	Metallic layers: – CD/DVD/Blu-ray, hard drives and read heads
<b>Display</b>	Functional layers – TFT-flat screen monitors, touch panel displays for smartphones and tablet computers
<b>Large area coating</b>	Coating to influence transmission (translucence) and conductance: – Building and automobile glass
<b>Film coating</b>	Flexible layers e.g. for decoration or diffusion barrier for oxygen and moisture: – Food packaging, wrapping paper
<b>Solar</b>	Functional layers – Thin film solar cells, solar wafers
<b>Lighting</b>	Light emitting coatings – LED light emitting diodes, OLED light emitting diodes



**Vacuum coating applications**

- Coating of heat protection glass, eyeglass lenses and other special glass types
- Semiconductor, solar cell and mobile telephone production
- Flat-screen television, DVD or Blu-ray disc production
- Thanks to vacuum coating, metal parts can be replaced with lighter plastic parts in the automobile industry as well as in the industrial toolmaking and mechanical engineering sector
- Basis for high precision measuring and control in mass spectrometry and gas chromatography

**Coating products**

Rotary vane pumps	Diaphragm vacuum pumps	Screw pumps	Side channel pumps	Multi-stage Roots pumps	Roots pumps	Roots pumping stations	Turbopumps	Turbo pumping stations	Measurement equipment	Analysis equipment	Leak detectors	Systems	Chambers	Components	Valves	Feedthroughs	Manipulators
																	
						■	■				■		■	■	■	■	
						■	■				■		■	■	■	■	
						■	■				■		■	■	■	■	
						■	■				■		■	■	■	■	
						■	■				■		■	■	■	■	
■							■				■		■	■	■	■	■
		■		■			■			■	■		■	■	■	■	■
						■	■			■	■		■	■	■	■	■
						■	■			■	■		■	■	■	■	■
		■		■		■	■			■	■		■	■	■	■	■
		■		■			■			■	■		■	■	■	■	■



## 5. Product safety at Pfeiffer Vacuum

Safety for high demands

Our vacuum solutions range from the selection of individual components to complete vacuum systems. Important to note: The more complex the product, the more important product safety becomes. Safe products create a high level of protection for employees and long system life – so safety does have a direct impact on the economic feasibility of a product.

#### **Our vacuum solutions are efficient and safe**

Product safety in the European Union is primarily influenced by the EC directives, which we adhere to as a matter of course.

Many products are also certified in accordance with Underwriters Laboratories (UL) and SEMI guidelines and standards (SEMI = Semiconductor Equipment and Materials International). For example, our turbopumps meet the UL 61010 and SEMI S2 guidelines.

At [www.pfeiffer-vacuum.com](http://www.pfeiffer-vacuum.com), our multi-lingual technical documents are ready for your download.

EC directives, depending on which of our products are used:

<b>Directive</b>	<b>Application to</b>
2006/42/EC	Machinery and partly completed machinery
2006/95/EC	Electrical devices of 50 to 1,000 V AC or 75 to 1,500 V DC
2004/108/EC	Electromagnetic compatibility
97/23/EC	Pressure devices (overpressure >500 hPa)
2009/105/EC	Simple pressure vessels

#### **Risk assessment in accordance with EN ISO 12100 “Safety of machinery”**

Whenever individual products are combined with one another, tests need to be conducted to determine whether new risks are generated as a result of the new structure. Thanks to our extensive total solution program, we offer you the opportunity to acquire all relevant parts of a vacuum system from a single source – a huge advantage when it comes to assessing and guaranteeing product safety, since all the data needed to carry out a risk assessment in accordance with EN ISO 12100 can be obtained from the same source. Upon request, we will carry out an individual safety assessment for any combination of our products and then supply you with a corresponding solution. For example, we can manufacture vacuum chambers that perfectly adjust to the particular turbopump in use and whose connection flanges are able to cope with extraordinary loads during unusual events.

#### **After sales service comes naturally to us**

In the event of serious changes to your vacuum system, we are happy to assist with expert advice.

#### **This is who we are – an overview of our strengths:**

- Vacuum solutions from a single source – safe vacuum systems thanks to our extensive product range and components tested for safety
- As experts in vacuum solutions, we provide individual project consultation
- CE adherence and safety tested systems
- Additional safety certification for many products
- After-sales service provides you support when making adjustments to your current vacuum system

## 6. Pfeiffer Vacuum product range: Vacuum generation

Single-stage and two-stage rotary vane pumps





## Single-stage rotary vane pumps

HenaLine	Advantages	Benefits
	■ Low oil filling level	■ Reduced operating costs
	■ Water cooling available upon request	■ Allowing applications under the hardest conditions with high thermal loads
	■ Long oil life	■ Cost savings through extended maintenance intervals
	■ Low vibration during operation due to reduced mass	■ Operation and process reliability; no installation of vibration dampers needed

UnoLine Plus	Advantages	Benefits
	■ Robust through minimal wear	■ Long lifetime
	■ Resistant to dirt and grime	■ Maximum process suitability
	■ Low rotation speeds	■ Low power consumption
	■ Extremely high water vapor capacity	■ Ideally suited for drying processes

## Two-stage rotary vane pumps

PentaLine®	Advantages	Benefits
	■ Efficient motors with 50% energy savings in accordance with IE3	■ Reduced operating costs
	■ No abrading seals between the pump system and drive	■ No premature maintenance stoppages
	■ Long life, as no oil leaks result from wear	■ Low service costs
	■ Extremely low vibrations	■ Ultra-quiet operation (particularly in standby)

DuoLine™	Advantages	Benefits
	■ Hermetically sealed	■ High operating safety
	■ Standard magnetically coupled (M), corrosive gas version magnetically coupled (MC) available	■ Optimal adaptation to your processes
	■ Compact design	■ Simple system integration
	■ No maintenance of shaft seal rings (for M and MC)	■ Cost savings for each pump and maintenance interval

Pascal <sup>1)</sup>	Advantages	Benefits
	■ Low back diffusion thanks to passive safety valve	■ High reliability for your processes
	■ Easy access to all control elements and service ports through practical placement on the front side	■ Easy to use and integrate
	■ Gas ballast valve allows high gas flows	■ High water vapor tolerance
	■ Hardly any abrading parts	■ Low cost of ownership and easy maintenance



<sup>1)</sup> Various versions available:

- **SD version** for all vacuum applications with non-corrosive gases
- **I version** with additional oil pump for the requirements of instrumental analytics
- **C1 version** for applications with aggressive or corrosive gases
- **C2 version** for harsh duty applications with the most aggressive pumping environment

## 6. Pfeiffer Vacuum product range: Vacuum generation

Diaphragm pumps, screw pumps, side channel pumps



MVP diaphragm pumps	Advantages	Benefits
	■ Operation free of return flow	■ High reliability of your processes
	■ Energy efficiency through low power consumption	■ Low operating costs
	■ Long diaphragm service life	■ Long maintenance intervals
	■ Easy diaphragm and valve replacement	■ Very maintenance friendly
HeptaDry® screw pump	Advantages	Benefits
	■ Energy saving operation through optimal rotor geometry	■ Low cost of ownership
	■ No contact between operating fluid and process gas	■ No disposal costs for operating fluids in this process
	■ Contact free, low-wearing sealing process	■ Cost savings through extended maintenance intervals
	■ Tolerant of dirt and contamination	■ High reliability of your processes
OnTool Booster	Advantages	Benefits
	■ Compact design, high vacuum flange in 3 positions	■ Easy system integration
	■ Very quiet operation thanks to high frequency gas vibrations	■ Flexible use, e.g. as tabletop pump or in the lab
	■ Pump for high vacuum, sealing directly against atmosphere of >1100 hPa	■ Cost savings since the backing pump is not needed
	■ Extremely low vibrations	■ High reliability and suitable for use in plants

## 6. Pfeiffer Vacuum product range: Vacuum generation

### Multi-stage Roots pumps







## Clean processes

ACP 15 – 40 <sup>1)</sup>	Advantages	Benefits
	■ Pump system runs contact-free	■ Improvement of process quality through oil and particle free vacuum
	■ Long maintenance intervals	■ Low operating costs
	■ No dynamic loads on the seals in the pump block	■ Consistent long-term performance
	■ One-phase grid connection	■ Very easy installation

A 100 L <sup>2)</sup>	Advantages	Benefits
	■ Particularly efficient in version A 100 L ES	■ Up to 50% lower operating costs
	■ Compact, stackable, optimized installation	■ Simple, flexible system integration
	■ Extremely space-saving	■ Cost savings in clean rooms through reduced space requirements
	■ On-tool assembly due to quiet operation and low vibration; oil and particle-free	■ Improves process quality in clean room

ACP 120, ACG 600	Advantages	Benefits
	■ Long maintenance intervals (up to four years)	■ Low service costs
	■ Oil and particle-free vacuum thanks to wear-free pump block	■ Increased process quality
	■ High tightness of motor and pump block	■ No contamination of your products
	■ Compact design	■ Compact system integration

## Medium duty applications

A3P	Advantages	Benefits
	■ Compact design and light weight, same dimensions for all pumps in the series	■ Simple system integration and replacement within the series
	■ High corrosion resistance	■ Long life
	■ Integrated silencer	■ Low noise levels
	■ Low power consumption, low purge gas consumption and low cooling water needs	■ Low operating costs

## Harsh duty applications

A3H	Advantages	Benefits
	■ High powder and dust tolerance	■ Unrivaled durability
	■ Frequency converter for Roots pumps	■ High flexibility in process execution
	■ Optimized temperature management	■ Individual adaptation to your processes possible
	■ Explosion resistant up to 20 bar static pressure	■ Greatest possible safety even with explosive media

<sup>1)</sup> Various versions available:

- **SD version** for applications with dust-free inert gases
- **G version** for use with low quantities of corrosive gases
- **CV version** for applications with condensable vapors

<sup>2)</sup> in variant A 180 L designed with increased pumping speeds of 180 m<sup>3</sup>/h and for frequent pumpdown cycles

## 6. Pfeiffer Vacuum product range: Vacuum generation

### Roots pumps



## Convection cooled

OktaLine®	Advantages	Benefits
	<ul style="list-style-type: none"> <li>■ No cooling water due to air cooling</li> </ul>	<ul style="list-style-type: none"> <li>■ Reduced operating costs</li> </ul>
	<ul style="list-style-type: none"> <li>■ Robust structure thanks to field-tested design</li> </ul>	<ul style="list-style-type: none"> <li>■ Long lifetime</li> </ul>
	<ul style="list-style-type: none"> <li>■ Short pumpdown times (pumping speeds of up to 27,000 m<sup>3</sup>/h)</li> </ul>	<ul style="list-style-type: none"> <li>■ Process optimized through reduced cycles</li> </ul>
	<ul style="list-style-type: none"> <li>■ Protected against thermal overload</li> </ul>	<ul style="list-style-type: none"> <li>■ High reliability</li> </ul>

## Gas-circulation-cooled

OktaLine® G	Advantages	Benefits
	<ul style="list-style-type: none"> <li>■ High differential pressures possible</li> </ul>	<ul style="list-style-type: none"> <li>■ Cost savings as backing pump is not needed</li> </ul>
	<ul style="list-style-type: none"> <li>■ Oil-free workspace</li> </ul>	<ul style="list-style-type: none"> <li>■ Clean removal of environmentally harmful media</li> </ul>
	<ul style="list-style-type: none"> <li>■ Process temperature regulation eliminates residue in the pump</li> </ul>	<ul style="list-style-type: none"> <li>■ High stability for your processes</li> </ul>
	<ul style="list-style-type: none"> <li>■ Energy efficient standard drive</li> </ul>	<ul style="list-style-type: none"> <li>■ Low cost of ownership</li> </ul>

## Explosion protection

OktaLine® ATEX <sup>1)</sup>	Advantages	Benefits
	<ul style="list-style-type: none"> <li>■ Contact-less, wear-free cam shaft version</li> </ul>	<ul style="list-style-type: none"> <li>■ Increased explosion protection as pressure surge resistance is up to 160 kPa</li> </ul>
	<ul style="list-style-type: none"> <li>■ Robust structure thanks to practice-tested design</li> </ul>	<ul style="list-style-type: none"> <li>■ Long life</li> </ul>
	<ul style="list-style-type: none"> <li>■ No cooling water due to air cooling</li> </ul>	<ul style="list-style-type: none"> <li>■ No costs for cooling water</li> </ul>
	<ul style="list-style-type: none"> <li>■ No thermal overload thanks to integrated temperature sensor</li> </ul>	<ul style="list-style-type: none"> <li>■ High reliability for your processes</li> </ul>

<sup>1)</sup> Explosion protection for zones 2 and 3 available

# 6. Pfeiffer Vacuum product range: Vacuum generation

## Roots pumping stations

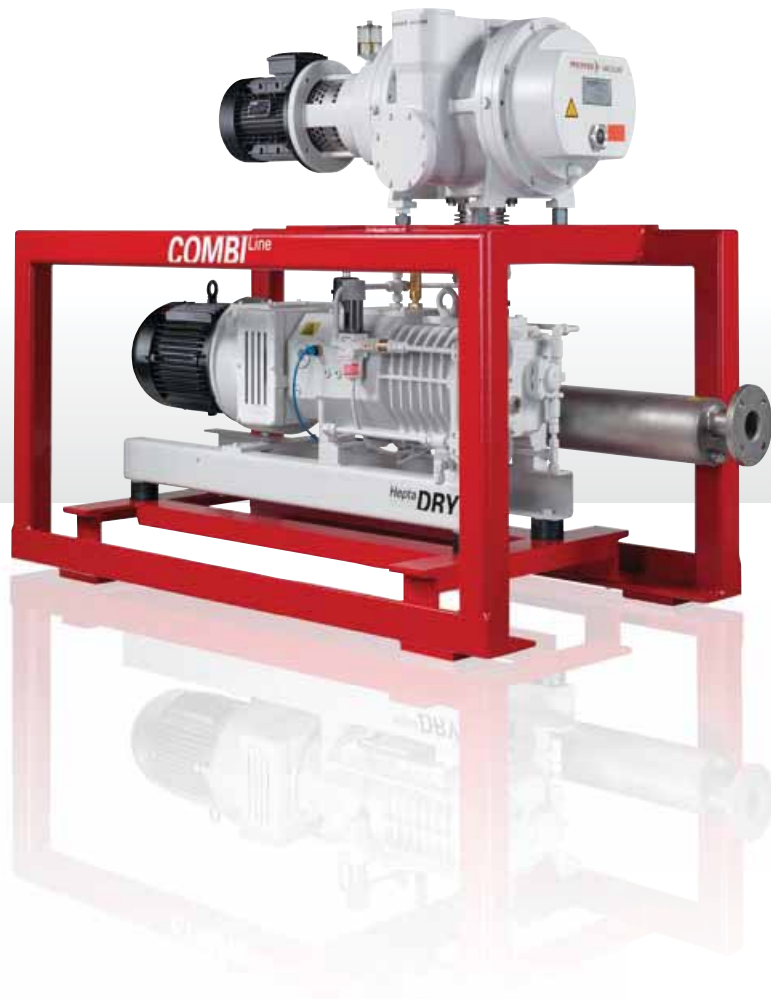

## Oil-free

CombiLine WH	Advantages	Benefits
	<ul style="list-style-type: none"> <li>■ Various pump and accessory combinations possible</li> </ul>	<ul style="list-style-type: none"> <li>■ Optimal adaptation to your processes</li> </ul>
	<ul style="list-style-type: none"> <li>■ Energy-saving operation</li> </ul>	<ul style="list-style-type: none"> <li>■ Low cost of ownership</li> </ul>
	<ul style="list-style-type: none"> <li>■ No contact between operating fluid and process gas</li> </ul>	<ul style="list-style-type: none"> <li>■ No disposal costs for operating fluids in this process</li> </ul>
	<ul style="list-style-type: none"> <li>■ Contact-free low wear sealing process</li> </ul>	<ul style="list-style-type: none"> <li>■ Cost savings through extended maintenance intervals</li> </ul>

DRS	Advantages	Benefits
	<ul style="list-style-type: none"> <li>■ Oil-free and particle-free vacuum</li> </ul>	<ul style="list-style-type: none"> <li>■ Increased process quality</li> </ul>
	<ul style="list-style-type: none"> <li>■ High long-term stability thanks to pump block with no parts subject to wear</li> </ul>	<ul style="list-style-type: none"> <li>■ Best possible reproducibility of your processes</li> </ul>
	<ul style="list-style-type: none"> <li>■ Long maintenance intervals (up to four years)</li> </ul>	<ul style="list-style-type: none"> <li>■ Low service costs</li> </ul>
	<ul style="list-style-type: none"> <li>■ High leak-tightness of both vacuum pumps</li> </ul>	<ul style="list-style-type: none"> <li>■ No contamination of your processes</li> </ul>

## 6. Pfeiffer Vacuum product range: Vacuum generation

### Roots pumping stations

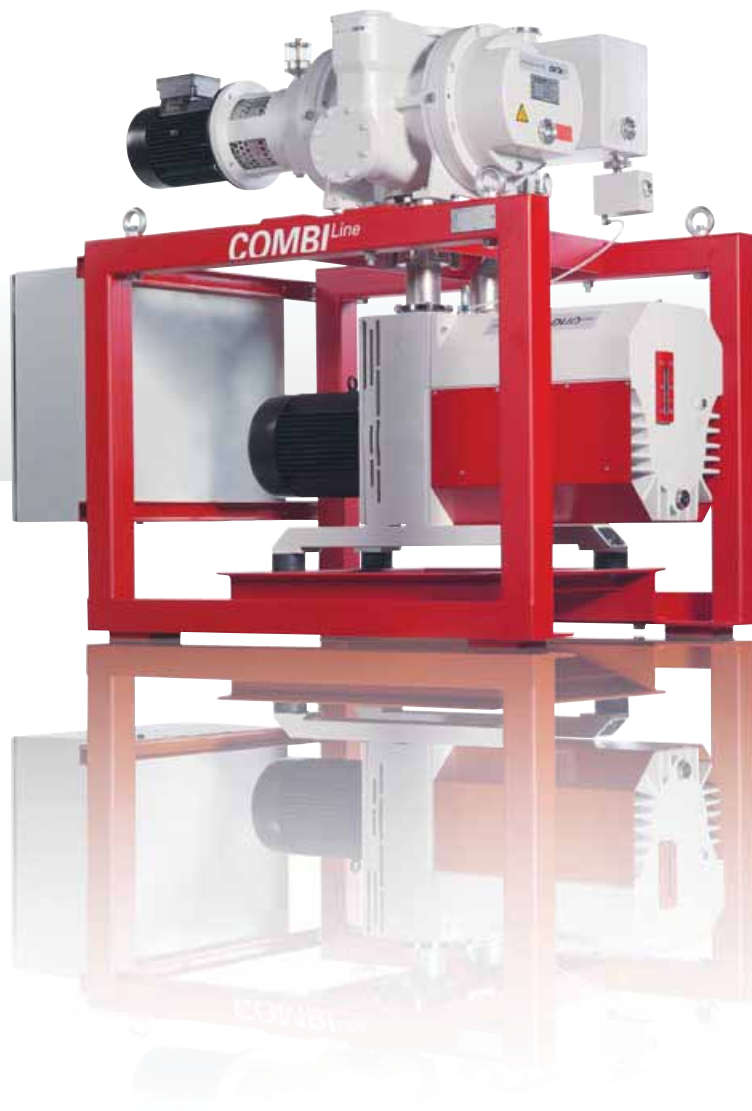



## Oil-lubricated

CombiLine WU	Advantages	Benefits
	<ul style="list-style-type: none"> <li>■ Various pump and accessory combinations possible</li> </ul>	<ul style="list-style-type: none"> <li>■ Optimal adaptation to your processes</li> </ul>
	<ul style="list-style-type: none"> <li>■ Optimized design</li> </ul>	<ul style="list-style-type: none"> <li>■ Simple service</li> </ul>
	<ul style="list-style-type: none"> <li>■ Short pumpdown times through compression against atmosphere</li> </ul>	<ul style="list-style-type: none"> <li>■ Cost savings through reduced cycles</li> </ul>
	<ul style="list-style-type: none"> <li>■ High water vapor tolerance</li> </ul>	<ul style="list-style-type: none"> <li>■ Increased lifetime</li> </ul>

CombiLine WD	Advantages	Benefits
	<ul style="list-style-type: none"> <li>■ Various pump and accessory combinations possible</li> </ul>	<ul style="list-style-type: none"> <li>■ Optimal adaptation to your processes</li> </ul>
	<ul style="list-style-type: none"> <li>■ Small building space through reduced dimensions for pumping stations in this class</li> </ul>	<ul style="list-style-type: none"> <li>■ Simple integration into your system</li> </ul>
	<ul style="list-style-type: none"> <li>■ Clean exhaust through integrated oil mist separator</li> </ul>	<ul style="list-style-type: none"> <li>■ No exhaust treatment needed</li> </ul>
	<ul style="list-style-type: none"> <li>■ Magnetic coupling prevents wear on the camp shaft seals to the motor</li> </ul>	<ul style="list-style-type: none"> <li>■ Cost savings through extended maintenance intervals</li> </ul>

LRS 1	Advantages	Benefits
	<ul style="list-style-type: none"> <li>■ Very compact design</li> </ul>	<ul style="list-style-type: none"> <li>■ Simple integration into your system</li> </ul>
	<ul style="list-style-type: none"> <li>■ Special connection plate between the pumps</li> </ul>	<ul style="list-style-type: none"> <li>■ Reduced installation costs</li> </ul>
	<ul style="list-style-type: none"> <li>■ Mechanical overflow valve for the Roots pump</li> </ul>	<ul style="list-style-type: none"> <li>■ Uncomplicated operation even at high pressures</li> </ul>
	<ul style="list-style-type: none"> <li>■ Broad selection of operating fluids</li> </ul>	<ul style="list-style-type: none"> <li>■ Optimal adaptation to your processes</li> </ul>

LRS 2	Advantages	Benefits
	<ul style="list-style-type: none"> <li>■ Compact design with easily accessible components</li> </ul>	<ul style="list-style-type: none"> <li>■ Robust, reliable and easy to maintain</li> </ul>
	<ul style="list-style-type: none"> <li>■ Oil mist separator comes installed standard</li> </ul>	<ul style="list-style-type: none"> <li>■ No impairment of the workplace</li> </ul>
	<ul style="list-style-type: none"> <li>■ Equipped with rotary vane pump</li> </ul>	<ul style="list-style-type: none"> <li>■ Potential savings in energy costs and operating fluids</li> </ul>
	<ul style="list-style-type: none"> <li>■ Mechanical overflow valve for the Roots pump</li> </ul>	<ul style="list-style-type: none"> <li>■ Uncomplicated operations even at high pressures</li> </ul>

LRS 3	Advantages	Benefits
	<ul style="list-style-type: none"> <li>■ Compact design with easily accessible components</li> </ul>	<ul style="list-style-type: none"> <li>■ Robust, reliable and easy to maintain</li> </ul>
	<ul style="list-style-type: none"> <li>■ Available in standard or corrosive gas versions</li> </ul>	<ul style="list-style-type: none"> <li>■ Numerous possible applications</li> </ul>
	<ul style="list-style-type: none"> <li>■ Oil mist separator comes installed standard</li> </ul>	<ul style="list-style-type: none"> <li>■ No impairment of the workplace</li> </ul>
	<ul style="list-style-type: none"> <li>■ Optional control electronics</li> </ul>	<ul style="list-style-type: none"> <li>■ Numerous configuration possibilities for the individual fulfillment of your requirements</li> </ul>

# 6. Pfeiffer Vacuum product range: Vacuum generation

## Turbopumps







## With hybrid bearings

HiPace® 10 – 800	Advantages	Benefits
	<ul style="list-style-type: none"> <li>■ Compact design along with numerous mounting positions<sup>1)</sup></li> </ul>	<ul style="list-style-type: none"> <li>■ Minimal space requirements and simple system integration</li> </ul>
	<ul style="list-style-type: none"> <li>■ Bearing replacement on site</li> </ul>	<ul style="list-style-type: none"> <li>■ Cost savings through reduced service intervals</li> </ul>
	<ul style="list-style-type: none"> <li>■ Highest reliability thanks to robust design and proven bearing system</li> </ul>	<ul style="list-style-type: none"> <li>■ Long maintenance intervals</li> </ul>
	<ul style="list-style-type: none"> <li>■ Quick start-up due to high performance, integrated electronic drive unit</li> </ul>	<ul style="list-style-type: none"> <li>■ Reduced process times</li> </ul>

HiPace® 1200 – 2300	Advantages	Benefits
	<ul style="list-style-type: none"> <li>■ Robustness against particle problems</li> </ul>	<ul style="list-style-type: none"> <li>■ Long maintenance cycles</li> </ul>
	<ul style="list-style-type: none"> <li>■ Bearing replacement on site</li> </ul>	<ul style="list-style-type: none"> <li>■ Cost savings through reduced service intervals</li> </ul>
	<ul style="list-style-type: none"> <li>■ Various interface options available</li> </ul>	<ul style="list-style-type: none"> <li>■ Easy system integration</li> </ul>
	<ul style="list-style-type: none"> <li>■ Intelligent sensors through the implementation of appropriate parameters in the integrated electronics</li> </ul>	<ul style="list-style-type: none"> <li>■ Highest safety level</li> </ul>

SplitFlow™	Advantages	Benefits
	<ul style="list-style-type: none"> <li>■ Replaces several discrete turbopumps</li> </ul>	<ul style="list-style-type: none"> <li>■ Huge cost savings</li> <li>■ Significant improvement in reliability and faster service through reduced number of components</li> </ul>
	<ul style="list-style-type: none"> <li>■ Ball bearing replacement possible in installed pumps</li> </ul>	<ul style="list-style-type: none"> <li>■ System does not need to be taken apart</li> </ul>
	<ul style="list-style-type: none"> <li>■ Individual mechanical and vacuum design</li> </ul>	<ul style="list-style-type: none"> <li>■ Pump system optimally adapted to customer needs</li> </ul>

## With magnetically levitated bearings

HiPace® 300 – 800 M, ATH 500 M	Advantages	Benefits
	<ul style="list-style-type: none"> <li>■ Lower energy consumption through efficient magnetically levitating system</li> </ul>	<ul style="list-style-type: none"> <li>■ Low operating costs</li> </ul>
	<ul style="list-style-type: none"> <li>■ Magnetic levitation</li> </ul>	<ul style="list-style-type: none"> <li>■ Lower lifetime costs, as no maintenance required</li> </ul>
	<ul style="list-style-type: none"> <li>■ Low vibrations and low magnetic stray field</li> </ul>	<ul style="list-style-type: none"> <li>■ High reliability for your processes</li> </ul>
	<ul style="list-style-type: none"> <li>■ Additional speeds thanks to intelligent electronic drive unit</li> </ul>	<ul style="list-style-type: none"> <li>■ Cost savings as control valve is not needed</li> </ul>

ATH 1600 – 3200 M, ATP 2300 M	Advantages	Benefits
	<ul style="list-style-type: none"> <li>■ Magnetic levitation</li> </ul>	<ul style="list-style-type: none"> <li>■ Lower lifetime costs, as no maintenance required</li> </ul>
	<ul style="list-style-type: none"> <li>■ Intelligent sensors and electronics</li> </ul>	<ul style="list-style-type: none"> <li>■ High operating safety</li> </ul>
	<ul style="list-style-type: none"> <li>■ Freely selectable rotation speed in a broad RPM range</li> </ul>	<ul style="list-style-type: none"> <li>■ Optimized process adaptation</li> </ul>
	<ul style="list-style-type: none"> <li>■ Any mounting orientation</li> </ul>	<ul style="list-style-type: none"> <li>■ Easy system integration</li> </ul>

<sup>1)</sup> HiPace 300 C: 0° to 90° / HiPace Plus: 0°

## 6. Pfeiffer Vacuum product range: Vacuum generation

### Turbo pumping stations



**Compact**

HiCube® Eco	Advantages	Benefits
	■ Pumping station ready for operation	■ Plug and play – no installation or wiring needed
	■ Compact dimensions with low weight (17 kg)	■ Small, handy and portable
	■ No oil contamination thanks to dry sealed backing pump	■ No process impairments
	■ Perfectly coordinated individual components	■ Long life, high safety level and best reliability

**Standard**

HiCube® Classic	Advantages	Benefits
	■ Pumping station ready for operation	■ Plug and play – no installation or wiring needed
	■ Field-tested, robust construction	■ Reliable and safe
	■ Wide selection of pump combinations and options	■ Individual adaptation to your processes
	■ Perfectly coordinated individual components	■ Long life, high safety level and best reliability

**High performance**

HiCube® Pro	Advantages	Benefits
	■ Particularly fast pumpdown times due to the high pumping speed of the backing pump	■ Cost savings through time reductions
	■ Easy access to the individual components	■ Extremely service friendly
	■ Pumping station ready for operation	■ Plug and play – no installation or wiring needed
	■ Wide selection of pump combinations and options	■ Individual adaptation to your processes

# 6. Pfeiffer Vacuum product range: Vacuum measurement

Measurement equipment



**Digital**

DigiLine	Advantages	Benefits
	<ul style="list-style-type: none"> <li>■ Standard serial interfaces</li> <li>■ Data directly readable in PC or SPS</li> </ul>	<ul style="list-style-type: none"> <li>■ Low installation costs</li> <li>■ Secure data transmission thanks to digital signals</li> </ul>

**Analog**

ActiveLine	Advantages	Benefits
	<ul style="list-style-type: none"> <li>■ Compact design</li> <li>■ Large selection of vacuum gauges</li> </ul>	<ul style="list-style-type: none"> <li>■ Easy integration</li> <li>■ Flexible installation</li> </ul>

**Modular**

ModulLine	Advantages	Benefits
	<ul style="list-style-type: none"> <li>■ Rugged and well-proven design</li> <li>■ Tolerance for ionizing radiation</li> </ul>	<ul style="list-style-type: none"> <li>■ Field-tested long life</li> <li>■ Used in applications that place great demands on the vacuum technology</li> </ul>

## 6. Pfeiffer Vacuum product range: Analysis

Analytical equipment



## Residual gas analysis and gas analysis

PrismaPlus®	Advantages	Benefits
	<ul style="list-style-type: none"> <li>■ Modular design</li> <li>■ Ion sources with two filaments</li> </ul>	<ul style="list-style-type: none"> <li>■ Optimal adaptation to numerous measurement tasks</li> <li>■ High up-times</li> </ul>
OmniStar	Advantages	Benefits
	<ul style="list-style-type: none"> <li>■ Compact complete system</li> <li>■ Elaborated software</li> </ul>	<ul style="list-style-type: none"> <li>■ Low space requirements</li> <li>■ Easy to use even for quantitative gas analysis</li> </ul>
ThermoStar	Advantages	Benefits
	<ul style="list-style-type: none"> <li>■ Compact complete system, especially for coupling with thermo-balances</li> <li>■ Elaborated software</li> </ul>	<ul style="list-style-type: none"> <li>■ Low space requirements</li> <li>■ Easy to use even for quantitative gas analyses</li> </ul>



# 6. Pfeiffer Vacuum product range: Analysis

Analytical equipment





## Gas analysis

HPA	Advantages	Benefits
	<ul style="list-style-type: none"> <li>■ Numerous gas inlet options</li> <li>■ Compact dimensions</li> </ul>	<ul style="list-style-type: none"> <li>■ Individual adaptation to your measurement tasks</li> <li>■ Easy, flexible system integration</li> </ul>
SPM	Advantages	Benefits
	<ul style="list-style-type: none"> <li>■ Analysis in real time</li> <li>■ Compact dimensions</li> </ul>	<ul style="list-style-type: none"> <li>■ Fast, precise process monitoring</li> <li>■ Easy, flexible system integration</li> </ul>
HiQuad®	Advantages	Benefits
	<ul style="list-style-type: none"> <li>■ Extremely high measurement speed thanks to modern electronics</li> <li>■ High sensitivity along with large dynamic range thanks to precision mechanics and elaborated amplifier</li> </ul>	<ul style="list-style-type: none"> <li>■ Highly sensitive measurements in the lowest amount of time</li> <li>■ Excellent long-term stability</li> </ul>

## 6. Pfeiffer Vacuum product range: Leak detection

### Leak detectors



## Portable

MiniTest	Advantages	Benefits
	<ul style="list-style-type: none"> <li>Maximum test pressure of 200 hPa</li> </ul>	<ul style="list-style-type: none"> <li>Measurements possible even in vapor pipes and systems</li> </ul>
	<ul style="list-style-type: none"> <li>No mechanically moving parts</li> </ul>	<ul style="list-style-type: none"> <li>Low service costs thanks to long maintenance intervals</li> </ul>
	<ul style="list-style-type: none"> <li>Extraordinarily light (5 kg), small and compact</li> </ul>	<ul style="list-style-type: none"> <li>Usable in locations which are difficult to access</li> </ul>

ASM 310	Advantages	Benefits
	<ul style="list-style-type: none"> <li>Small, light (21 kg), compact</li> </ul>	<ul style="list-style-type: none"> <li>Easily carried to particular place of action</li> </ul>
	<ul style="list-style-type: none"> <li>Saving of measurements and configurations on SD card</li> </ul>	<ul style="list-style-type: none"> <li>Easy data documentation and process reproducibility</li> </ul>
	<ul style="list-style-type: none"> <li>Universal wide area network connection and multilingual user instructions</li> </ul>	<ul style="list-style-type: none"> <li>Simple use and easy operation in international environments</li> </ul>

## Multipurpose

ASM 340, ASM 340 D	Advantages	Benefits
	<ul style="list-style-type: none"> <li>Detection of large leaks up to 100 hPa</li> </ul>	<ul style="list-style-type: none"> <li>Unique range of applications</li> </ul>
	<ul style="list-style-type: none"> <li>Excellent connection compatibility to previous models</li> </ul>	<ul style="list-style-type: none"> <li>Existing accessories can be further used</li> </ul>
	<ul style="list-style-type: none"> <li>High performance vacuum system</li> </ul>	<ul style="list-style-type: none"> <li>Cost savings through reduced test intervals</li> </ul>
	<ul style="list-style-type: none"> <li>Oil-free in version 340 D</li> </ul>	<ul style="list-style-type: none"> <li>Use in clean applications</li> </ul>

## High performance – mobile

ASM 380	Advantages	Benefits
	<ul style="list-style-type: none"> <li>Extremely long maintenance intervals (20,000 operating hours)</li> </ul>	<ul style="list-style-type: none"> <li>Low life-time costs and long life</li> </ul>
	<ul style="list-style-type: none"> <li>Highest pumping speed of backing pump in its class (35 m<sup>3</sup>/h) as well as high helium pumping speed (7 l/s)</li> </ul>	<ul style="list-style-type: none"> <li>Fast and reliable leak detection</li> </ul>
	<ul style="list-style-type: none"> <li>Integrated closing storage space for tools, replacement parts and accessories</li> </ul>	<ul style="list-style-type: none"> <li>Practical access and quick availability of tools</li> </ul>

## High performance – compact

ASM 182 T, ASM 182 TD+	Advantages	Benefits
	<ul style="list-style-type: none"> <li>Pumping speed of backing pump: 20 m<sup>3</sup>/h</li> </ul>	<ul style="list-style-type: none"> <li>Quick pumpdown and short cycle times even for large components</li> </ul>
	<ul style="list-style-type: none"> <li>Folding front and back of the housing</li> </ul>	<ul style="list-style-type: none"> <li>Extraordinarily easy to maintain</li> </ul>
	<ul style="list-style-type: none"> <li>High helium pumping speed of 4.4 l/s</li> </ul>	<ul style="list-style-type: none"> <li>High detection sensitivity, even in serial testing</li> </ul>
	<ul style="list-style-type: none"> <li>Oil-free in version 182 TD+</li> </ul>	<ul style="list-style-type: none"> <li>Use in clean applications</li> </ul>

# 6. Pfeiffer Vacuum product range: Leak detection

## Leak detectors



## High performance – Console

ASM 192 T, ASM 192 T2D+	Advantages	Benefits
	<ul style="list-style-type: none"> <li>■ Backing pump speeds of up to 40 m<sup>3</sup>/h and helium pumping speeds of up to 4.4 l/s, in version 192 T2D+ with up to 50 m<sup>3</sup>/hh</li> </ul>	<ul style="list-style-type: none"> <li>■ Shortest pumpdown times and quick recovery times, even after intense signaling</li> </ul>
	<ul style="list-style-type: none"> <li>■ Optimal integration of test chambers</li> </ul>	<ul style="list-style-type: none"> <li>■ Cost-effective testing of encapsulated components through reduced cycle times</li> </ul>
	<ul style="list-style-type: none"> <li>■ Console form</li> </ul>	<ul style="list-style-type: none"> <li>■ Ergonomic workspace with high user friendliness</li> </ul>

## Workstation

ASM 1002	Advantages	Benefits
	<ul style="list-style-type: none"> <li>■ Backing pump speeds of up to 50 m<sup>3</sup>/h and high helium pumping speeds</li> </ul>	<ul style="list-style-type: none"> <li>■ Quick pumpdown as well as short cycle times</li> </ul>
	<ul style="list-style-type: none"> <li>■ Simple user interface (clear visual and audio signals)</li> </ul>	<ul style="list-style-type: none"> <li>■ High user friendliness</li> </ul>
	<ul style="list-style-type: none"> <li>■ Ten different test procedures can be saved</li> </ul>	<ul style="list-style-type: none"> <li>■ High reproducibility and process reliability</li> </ul>

## Modular

ASI 30	Advantages	Benefits
	<ul style="list-style-type: none"> <li>■ Compact, robust, modular system</li> </ul>	<ul style="list-style-type: none"> <li>■ Simple and compact integration in any mounting position</li> </ul>
	<ul style="list-style-type: none"> <li>■ Operation via PC or PLC possible</li> </ul>	<ul style="list-style-type: none"> <li>■ Cost savings as user panel is not needed</li> </ul>
	<ul style="list-style-type: none"> <li>■ Broad selection of interfaces and configurations</li> </ul>	<ul style="list-style-type: none"> <li>■ Best possible compatibility to your individual control concept</li> </ul>

## Sniffer leak detector

ASM 102 S	Advantages	Benefits
	<ul style="list-style-type: none"> <li>■ Small compact 19 inch rack housing with straps</li> </ul>	<ul style="list-style-type: none"> <li>■ Optimal carrying comfort for mobile sniffing leak detection</li> </ul>
	<ul style="list-style-type: none"> <li>■ Multi-language, simple user interface</li> </ul>	<ul style="list-style-type: none"> <li>■ Excellent user friendliness</li> </ul>
	<ul style="list-style-type: none"> <li>■ Robust industrial vacuum system</li> </ul>	<ul style="list-style-type: none"> <li>■ Storage, transport and measurement possible in any position</li> </ul>

# 6. Pfeiffer Vacuum product range: Systems

## System technology



Contamination management solutions

APA	Advantages	Benefits
	<ul style="list-style-type: none"> <li>■ No adjustment of FOUPs needed</li> </ul>	<ul style="list-style-type: none"> <li>■ Increases in wafer output</li> </ul>
	<ul style="list-style-type: none"> <li>■ Continuous analysis in real time</li> </ul>	<ul style="list-style-type: none"> <li>■ Immediate recognition of contaminations</li> </ul>
	<ul style="list-style-type: none"> <li>■ High throughput</li> </ul>	<ul style="list-style-type: none"> <li>■ Very short cycle times</li> </ul>

APR	Advantages	Benefits
	<ul style="list-style-type: none"> <li>■ Avoidance of process-side waiting times</li> </ul>	<ul style="list-style-type: none"> <li>■ Yield enhancement of up to 7%</li> </ul>
	<ul style="list-style-type: none"> <li>■ Best possible quality assurance with compact dimensions</li> </ul>	<ul style="list-style-type: none"> <li>■ Return on investment after six months</li> </ul>
	<ul style="list-style-type: none"> <li>■ Customized design possible</li> </ul>	<ul style="list-style-type: none"> <li>■ Individual adaptation to your processes</li> </ul>

Helium leak detection systems

Complete systems	Advantages	Benefits
	<ul style="list-style-type: none"> <li>■ Quick, fully automated testing</li> </ul>	<ul style="list-style-type: none"> <li>■ Minimizing of test periods and increase of output</li> </ul>
	<ul style="list-style-type: none"> <li>■ Helium recovery can be integrated as an option</li> </ul>	<ul style="list-style-type: none"> <li>■ Significantly lower operating costs</li> </ul>
	<ul style="list-style-type: none"> <li>■ Universal measuring procedures</li> </ul>	<ul style="list-style-type: none"> <li>■ Reduced error rates</li> </ul>

Helium recovery units

HRU	Advantages	Benefits
	<ul style="list-style-type: none"> <li>■ Standalone system</li> </ul>	<ul style="list-style-type: none"> <li>■ Independent of connected testing system</li> </ul>
	<ul style="list-style-type: none"> <li>■ Fully automated operation guarantees constant helium concentrations</li> </ul>	<ul style="list-style-type: none"> <li>■ Reproducible measurements in connected leak test systems</li> </ul>
	<ul style="list-style-type: none"> <li>■ Balloon or tank recovery</li> </ul>	<ul style="list-style-type: none"> <li>■ Individual solutions can be designed to meet your specific requirements</li> </ul>

Multi-stage vacuum process

Vacu <sup>2</sup>	Advantages	Benefits
	<ul style="list-style-type: none"> <li>■ Mold cavity and shot chamber in high pressure die cast systems are quickly evacuated</li> </ul>	<ul style="list-style-type: none"> <li>■ Avoidance of air bubbles in cast parts improves their quality</li> </ul>
	<ul style="list-style-type: none"> <li>■ Complete production monitoring</li> </ul>	<ul style="list-style-type: none"> <li>■ High process availability in high pressure die cast systems</li> </ul>
	<ul style="list-style-type: none"> <li>■ Very low vacuum</li> </ul>	<ul style="list-style-type: none"> <li>■ Quality improvements to the cast products</li> </ul>
	<ul style="list-style-type: none"> <li>■ High process stability in high pressure die cast systems</li> </ul>	<ul style="list-style-type: none"> <li>■ Cost savings through fewer rejects</li> </ul>

# 6. Pfeiffer Vacuum product range: Vacuum components

## Chambers





High vacuum chambers	Advantages	Benefits
	<ul style="list-style-type: none"> <li>■ Pre-configured design</li> </ul>	<ul style="list-style-type: none"> <li>■ Cost savings through lower design expenses</li> </ul>
	<ul style="list-style-type: none"> <li>■ Proven, tough format</li> </ul>	<ul style="list-style-type: none"> <li>■ Reliable and safe</li> </ul>
	<ul style="list-style-type: none"> <li>■ Selectable doors</li> </ul>	<ul style="list-style-type: none"> <li>■ Individual adaptation to your processes</li> </ul>

Medium vacuum chambers	Advantages	Benefits
	<ul style="list-style-type: none"> <li>■ Pre-configured design</li> </ul>	<ul style="list-style-type: none"> <li>■ Cost savings through lower design efforts</li> </ul>
	<ul style="list-style-type: none"> <li>■ Proven, tough design</li> </ul>	<ul style="list-style-type: none"> <li>■ Reliable and safe</li> </ul>
	<ul style="list-style-type: none"> <li>■ Selectable doors</li> </ul>	<ul style="list-style-type: none"> <li>■ Individual adaptation to your processes</li> </ul>

Modular vacuum chambers	Advantages	Benefits
	<ul style="list-style-type: none"> <li>■ Pre-configured design</li> </ul>	<ul style="list-style-type: none"> <li>■ Cost savings through lower design expenses</li> </ul>
	<ul style="list-style-type: none"> <li>■ Expansion and module replacement possible</li> </ul>	<ul style="list-style-type: none"> <li>■ Maximum flexibility at all times</li> </ul>
	<ul style="list-style-type: none"> <li>■ Selectable doors</li> </ul>	<ul style="list-style-type: none"> <li>■ Individual adaptation to your application</li> </ul>

Custom vacuum chambers	Advantages	Benefits
	<ul style="list-style-type: none"> <li>■ Individual design</li> </ul>	<ul style="list-style-type: none"> <li>■ Optimally adjustable to your process</li> </ul>
	<ul style="list-style-type: none"> <li>■ High quality materials</li> </ul>	<ul style="list-style-type: none"> <li>■ Best quality and long life-time</li> </ul>
	<ul style="list-style-type: none"> <li>■ Proven, tough design</li> </ul>	<ul style="list-style-type: none"> <li>■ Reliable and safe</li> </ul>

## 6. Pfeiffer Vacuum product range: Vacuum components

### Components



ISO-KF, ISO-K/ISO-F	Advantages	Benefits
	<ul style="list-style-type: none"> <li>■ Helium-leak tested components</li> <li>■ Large number of flange diameters</li> <li>■ Extensive, standardized system components</li> </ul>	<ul style="list-style-type: none"> <li>■ Fulfills high quality requirements</li> <li>■ Optimally suited for your vacuum system</li> <li>■ Perfect compatibility</li> </ul>

CF, COF	Advantages	Benefits
	<ul style="list-style-type: none"> <li>■ UHV suitable due to low desorption rates</li> <li>■ Helium-leak tested components</li> <li>■ Extensive, standardized system components</li> </ul>	<ul style="list-style-type: none"> <li>■ Creates uniquely clean vacuum</li> <li>■ Fulfills high quality requirements</li> <li>■ Perfect compatibility</li> </ul>

Viewports	Advantages	Benefits
	<ul style="list-style-type: none"> <li>■ Large selection of glass types</li> <li>■ Extensive, standardized system components</li> </ul>	<ul style="list-style-type: none"> <li>■ Suitable for a wide variety of applications</li> <li>■ Perfect compatibility</li> </ul>

Custom components	Advantages	Benefits
	<ul style="list-style-type: none"> <li>■ Development of specific components</li> <li>■ High quality materials</li> </ul>	<ul style="list-style-type: none"> <li>■ Customized components for your requirements</li> <li>■ Best quality and life</li> </ul>

## 6. Pfeiffer Vacuum product range: Vacuum components

### Valves



**Angle/inline valves and mini angle/inline valves****Advantages**

- Quick reaction due to short opening and closing times
- High number of switching operations
- Field-tested, robust construction

**Benefits**

- Can also be used in complicated processes
- Ideal for automation processes
- Reliable and safe

**HV/UHV gate valves****Advantages**

- High conductance value for molecular flows through free pass
- High number of switching operations
- Field-tested, robust construction

**Benefits**

- Guarantees optimal pump performance
- Ideal for automation processes
- Reliable and safe

**Gas dosing and gas regulating valves****Advantages**

- Variable gas throughput
- Large control range
- Field-tested, robust construction

**Benefits**

- Numerous applications
- Variable control options
- Reliable and safe

**Ball valves****Advantages**

- Robust construction
- Large, free feedthrough

**Benefits**

- Used both in fine vacuum as well as overpressure
- Guarantees optimal pump performance

## 6. Pfeiffer Vacuum product range: Vacuum components

### Feedthroughs and manipulators





## Feedthroughs

Electrical/thermocouple/fluid/ pipe feedthroughs, isolators	Advantages	Benefits
	<ul style="list-style-type: none"> <li>■ Large number in stock</li> <li>■ Large selection of various feedthroughs</li> </ul>	<ul style="list-style-type: none"> <li>■ High availability</li> <li>■ Customized applications also possible</li> </ul>

Rotary-/linear-/ rotary/linear feedthroughs	Advantages	Benefits
	<ul style="list-style-type: none"> <li>■ Field-tested design</li> <li>■ Large selection of various feedthroughs</li> </ul>	<ul style="list-style-type: none"> <li>■ High reliability</li> <li>■ Customized applications also possible</li> </ul>

## Manipulators

Z-/XY-/XYZ-axis manipulators, rotary/adjustment manipulators	Advantages	Benefits
	<ul style="list-style-type: none"> <li>■ Extremely precise thanks to high degree of inherent rigidity and precise movements</li> <li>■ Use of mechanical components with low wear</li> <li>■ Field-tested design</li> </ul>	<ul style="list-style-type: none"> <li>■ Highest precision and excellent reproducibility</li> <li>■ Very long lifetime</li> <li>■ High reliability</li> </ul>

Custom manipulators	Advantages	Benefits
	<ul style="list-style-type: none"> <li>■ Individual design</li> <li>■ Proven, tough design</li> <li>■ Easy to combine with other Pfeiffer Vacuum products</li> </ul>	<ul style="list-style-type: none"> <li>■ Optimal process adjustment</li> <li>■ Reliable and safe</li> <li>■ Excellent adaptation to your process components</li> </ul>



# 7. Vacuum as a basis for our modern life

Into the future with Pfeiffer Vacuum products







Vacuum is essential for the manufacture of high-tech products used in our daily lives. Through our innovative and individual vacuum solutions, we implement future-oriented ideas and offer a complete range of support.

In doing so, we place great demands on our products to make sure they meet our customer's requirements and implementation needs. From development to servicing, our solutions reflect the art of German engineering with highest quality standards, competent advice and reliable service. Our products are continually optimized through close cooperation with our customers from a wide variety of industries. Thanks to years of experience, we perfectly meet the needs of our customers when it comes to evacuating, measuring and analyzing.

Without Pfeiffer Vacuum products, many items of our everyday life would not be available:

- Tools
- Jewelry
- Eyeglass lenses
- DVD-RW
- Wrapping paper
- Wheel rims
- Barrels
- Car parts
- Railroad rails
- Instant products
- Pharmaceutical products
- Freeze drying
- Vacuum drying



## 8. Energy Efficiency as our company philosophy

**How sustainability and resource conservation shape our actions**

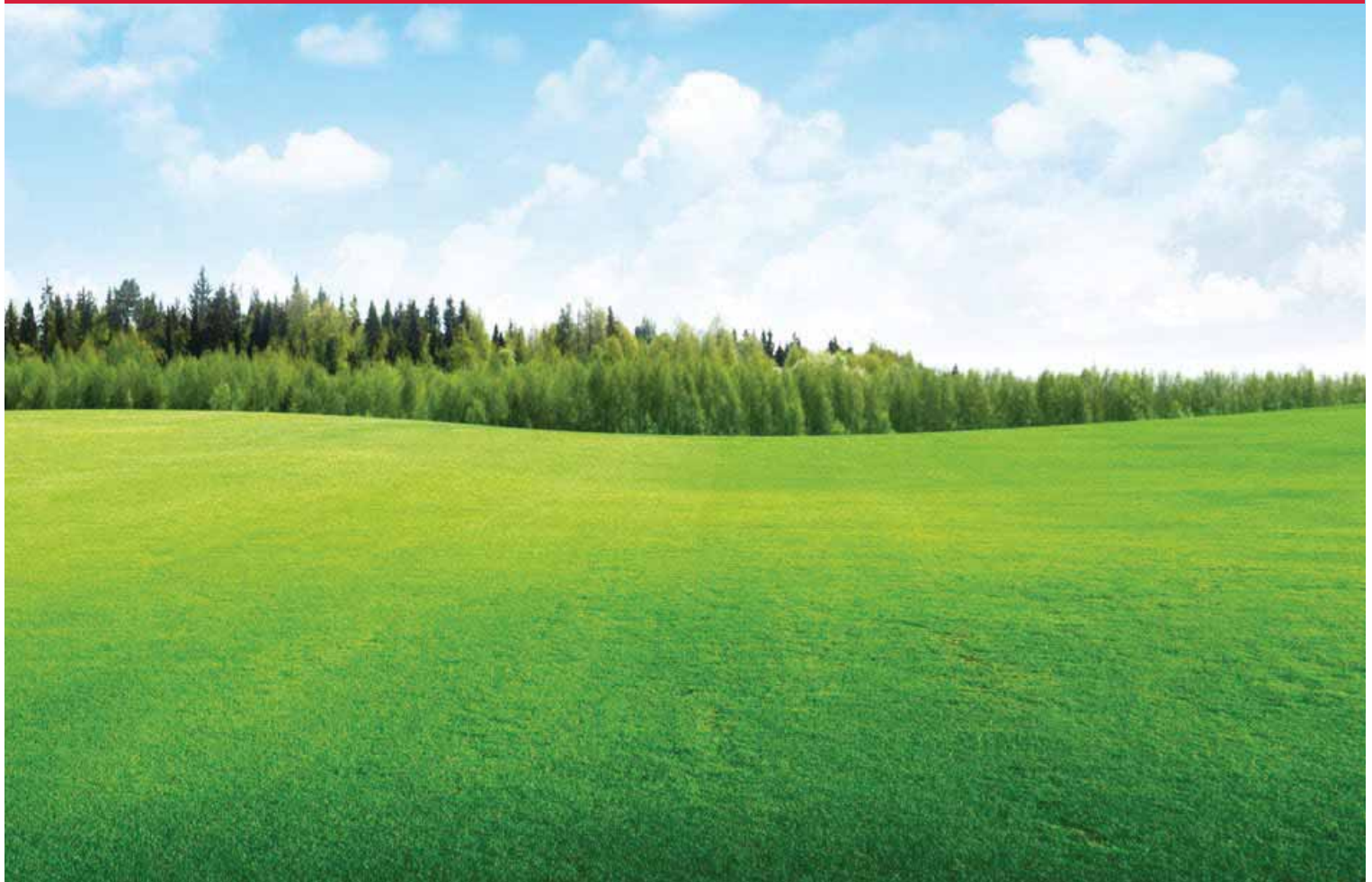

To fulfill our promise of high quality products, our vacuum solutions face the most demanding requirements. Therefore, the topic of energy efficiency plays an important role. Our experts integrate efficient technologies and innovative ideas for saving energy into the development process of a product. It serves as the basis for the entire production process.

Our goal is to provide sustainable solutions for our customers while meeting the tough requirements of various industries and applications and moreover generate true added value. The efficiency of our products contributes to significant energy savings in daily operations resulting in considerable savings of cost of ownership.

In addition, our commitment to energy efficiency also helps us fulfill our ecological responsibility. The conscientious handling of limited resources, the use of recyclable materials, a well-designed waste management system as well as our employees' awareness of the use of energy and environmentally friendly materials illustrate that energy efficiency and sustainability is important to us. Our company processes are based on the ISO 14001 standard.

#### **Energy efficient products of Pfeiffer Vacuum**

Our products are the heart of the company. With them, we meet the highest standards and offer our customers a comprehensive vacuum solution fulfilling their specific application requirements. Furthermore, we stand for added value thanks to energy saving technologies, which lower costs and increase efficiency.

To reach this goal, our product developers utilize the latest standards for improving efficiency:

- Freely levitating magnetic bearings in many of our turbopumps reduce friction resulting in lower energy consumption
- Use of the energy saving BLDC (installed, brushless) direct current motors in many turbopumps
- Up to 90% savings in overall energy consumption through the use of the interval principle in all turbopumps: If there are low gas emissions from the chamber, the backing pump is switched off; when the gas increases to a specific level, the pump will restart
- Reduced material consumption
- Standby mode with reduced rotation speeds for many pump models
- Intelligent energy supply of the electromagnetic valves in leak detectors: Full power only at activation, afterwards 7-fold reduction for continued operation
- For larger valves, use of vacuum energy from an integrated vacuum pump



# 8. Energy Efficiency as our company philosophy

## Energy efficiency and conservation of resources at Pfeiffer Vacuum



The creation of efficient products with greatest benefit to our customers as well as the fulfillment of our ecological responsibility require our full commitment. Energy efficiency and the conscientious use of natural resources are the cornerstones of our company, which we live and work for every day. This philosophy can be found not only in the efficient vacuum solutions for our customers but also in every link of the value chain as well as in our employees' attitudes.

### Energy efficiency in development and production

Early in the planning stage of a new product, energy efficiency and resource conservation play an important role. At Pfeiffer Vacuum, a product is examined in terms of energy efficiency from development to recycling:

- "Eco-design" is an inherent part of the development process.  
In each new project, three ecological aspects are optimized, including:
  - Energy consumption
  - Reduction of product weight
  - Reduction of the usage of environmentally damaging materials (copper, steel, ...)
  - Reduction of surface treatments with negative environmental impact
- Specifications for the development processes include the topic of energy efficiency
- Suppliers are selected with regard to energy efficiency
- Possible savings in product design, operation and maintenance are analyzed

We therefore can be certain that our products provide our customers with huge advantages from the very start: cost savings, space and time saving processes as well as the resulting efficiency in production output provides additional value.

### Production processes

Not only do we consider the importance of an efficiently designed product in operation at our customers' sites, we also strive to make our production processes as efficient as possible.

Thanks to sustainable production processes, we can reinforce our quality promise and guarantee our customers the greatest level of efficiency from production to service. In addition, we thereby contribute directly to the conservation of energy and resources.



For us, efficient production means:

- Electrical energy recovery in a large number of our machines
- Multiple processing in a single machine
- Use of energy saving machines
- Energy-optimized coolant supply through consumption-controlled pump operations
- No use of solvent-based cleaning systems
- Recycling of processed materials
- Heavily insulated production halls and buildings
- Energy efficient lighting
- Water recovery systems
- Storage of waste materials in a recovery station and recycling



### Environmental protection is a vital component of our company philosophy

We provide precisely coordinated processes for energy savings and resource conservation not only for our products, but also for their development and production. Sustainability is important for the entire company worldwide. A fixed part of our company strategy is our environmental management certified according to ISO 14001, which deals with a holistic examination of all environmentally relevant areas. Pfeiffer Vacuum documents all effects that impact the environment to reduce and avoid any damage.

- The entire heating system at the headquarters in Asslar, Germany, uses condensing boiler technology
- Additionally, the facility also has a 750 m<sup>2</sup> photovoltaic array with 1,003 solar modules producing 75 kWp
- It produces 100,000 kWh a year, which is fed directly into the local power supply
- This leads to an annual emission reduction of approx. 53 t CO<sub>2</sub>
- By the aid of of EcoWebDesk, a precise monitoring of all waste and hazardous materials, energy consumption values, legal regulations, as well as external audits can be conducted
- Hot water is provided only as needed using modern supply technology
- Heat exchange systems for cooling water use
- Use of LED technology

The most important resource of a company is its **employees** – this is also true for us. Their involvement and work is a core requirement for living our passion for perfection. The same also applies to energy and environmental consciousness. We thus regularly provide our employees with information about current energy and environmental guidelines, hazardous materials management and efficiency aspects of our products.

But also individual initiative is still required: projects such as the energy consumption analysis for the “Switch off” campaign during the state of Hesse’s 2012 Sustainability Day helped to raise employee awareness of their energy consumption and highlight potential savings.





## 9. Pfeiffer Vacuum consulting

**Expertise, science and customer proximity is an essential part of the solution program**

Thanks to over 120 years of experience in vacuum technology and the role as technological leader in the vacuum industry, Pfeiffer Vacuum has attained a high level of skill and consulting competence. We offer our expertise as an integral part of our complete solutions, providing competent support from the very beginning.

- Our complete catalog, including the extensive chapter in vacuum technology, provides basic vacuum knowledge as well as information about our products and their applications that is suitable both for research and practice
- Our experts in customer service, with their tremendous amount of expertise in vacuum technology, will provide assistance from design to system service.
- Our eVacuum information service on the Internet provides information about vacuum technology, extending beyond product information. Find out more about our extensive online advisory service on the next page!



## 9. Competent advice at Pfeiffer Vacuum: eVacuum app and internet

**Vacuum support at your fingertips!**

Using our **eVacuum app** allows for quick and easy access to all sorts of information. The only thing you need is an iPhone, an iPad, an Android phone or a tablet PC.

Contents:

- Product catalog: Every product with a picture, description, technical data and drawings
- Product selector: In a flash you can find the solution you're looking for
- Vacuum Compendium: The proven handbook for vacuum practice
- Unit converter: For all common pressure units in exponential terms
- Sales and service contacts: All locations in a clear customer presentation
- The latest news about the company and the world of vacuum



iPhone



iPad



Android



NORM Electronics LTD [www.norm.gr](http://www.norm.gr)



[www.pfeiffer-vacuum.com](http://www.pfeiffer-vacuum.com)





In addition to the use of our app, Pfeiffer Vacuum's **Internet presence** offers extensive information. You can use it to find out all important information about our products, possible applications, methods of ordering and downloading of additional literature, detailed information on servicing and much more. See for yourself by visiting [www.pfeiffer-vacuum.com](http://www.pfeiffer-vacuum.com)!

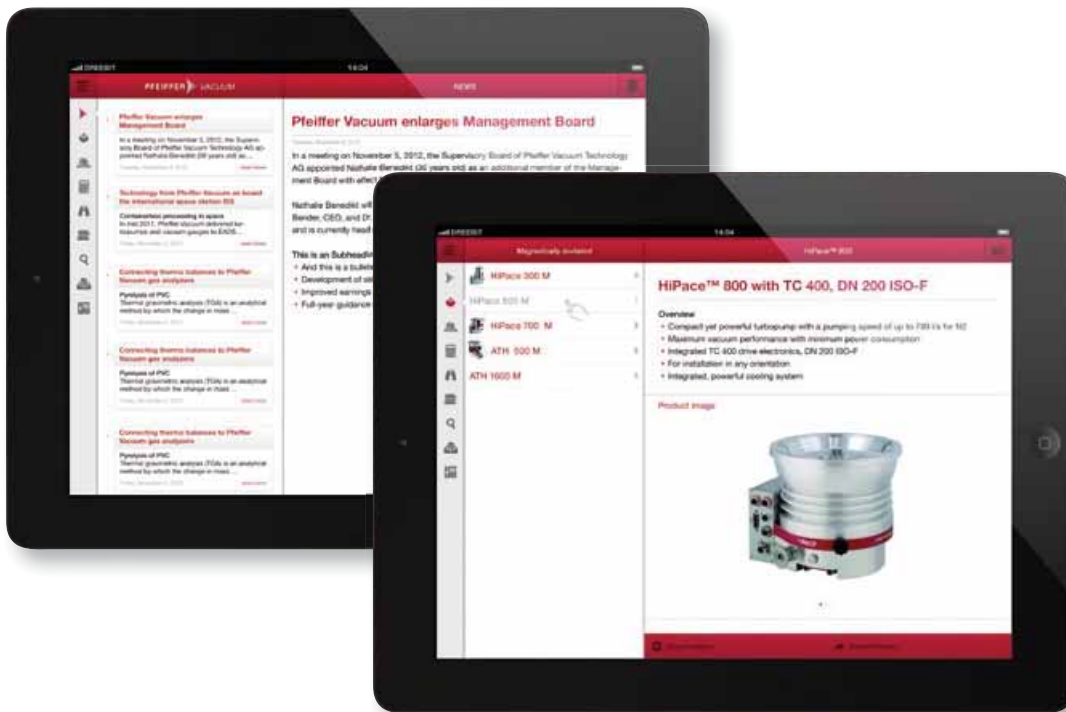



## 10. Pfeiffer Vacuum service solutions

**First-class service for high-quality products.  
Fast. Reliable. Efficient.**



Extended vacuum component service life, coupled with minimal downtimes, is what you can expect from us. We satisfy your requirements with high-performance products and excellent service.

Our extensive range of training courses provides you with the best possible expertise for safeguarding against the dreaded "worst-case scenario" and to perfect the way you handle vacuum components.

Our professional sales engineers and service technicians provide you with hands-on support world-wide.

Pfeiffer Vacuum offers a complete service portfolio ranging from genuine spare parts right through to service agreements: The modular service system is adjusted precisely to your needs.

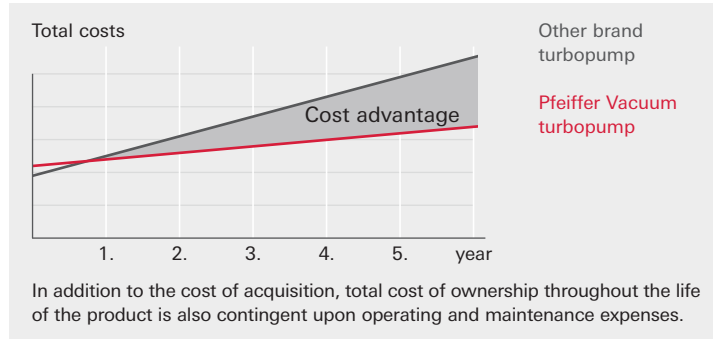

# 10. Pfeiffer Vacuum service solutions: Range of services

**Fast, competent service around the globe**

## **Training**

Qualified staff is vital to guarantee the smooth operation of our vacuum solutions in your company. We offer you training courses for every need, covering a wide variety of topics: spanning from theoretical basic courses up to application training courses that provide you with the skills to maintain your systems. Make sure your staff has the vacuum expertise you need!

In addition to the regular training courses, arrangements for individual courses can be made. Necessary for all courses: Practice based focus is vital. All courses can take place either in our company headquarters in Asslar, Germany, or on site at your company. More information about our training courses can be found in our customer training course program on our website.

## **Genuine replacement parts and tools**

For carrying out some common maintenance items yourself, we recommend that you only use genuine replacement parts and tools. These are available from Pfeiffer Vacuum and will ensure the quality and long life of our products. All of our experience that we have gathered in the development and production of our components is used in putting together replacement part packages and the development of our tools. Our promise: All genuine replacement parts and tools are state-of-the-art.





**Preventative service**

Optimal maintenance is important to guarantee the best possible functionality of our products. To reduce downtimes as much as possible, Pfeiffer Vacuum can maintain many of our products directly on-site at your company. For preventative maintenance, we offer a lower-priced service replacement; you receive an exchange product tested to the latest specifications. We can also create your own individual service schedule within the frame of a service agreement and support you in monitoring maintenance intervals.



**Corrective service**

If maintenance is no longer sufficient, we will do everything to make sure your product is up and running once again. With more than 80 service locations worldwide, we are ready to provide a quick solution nearby using uniform standards. If a quick turnaround time is needed, we will be happy to provide you with a replacement product in mint condition.

**Refurbished products**

Another choice is our refurbished products that also meet the highest quality standards. These products are in perfect technical condition and are tested according to new product criteria. Our customer service department will be happy to issue you a quote and check for immediate availability.

**Additional services**

Additional on-site services include the commissioning of components and systems, gas analysis and leak detection on site as well as the calibration of vacuum gauges and test leaks. Any short-term requirements can be accommodated through the rental of your required product.

# ▶ 11. On-site worldwide for you

Production, sales and service



● Sales and service  
■ Production

**Germany**

Pfeiffer Vacuum Technology AG  
Pfeiffer Vacuum GmbH  
Asslar  
info@pfeiffer-vacuum.de

Pfeiffer Vacuum GmbH  
Sales & Service  
Wertheim  
info@pfeiffer-vacuum.de

Trinos Vakuum-Systeme GmbH  
Anna-Vandenhoeck-Ring 44  
Goettingen  
info@trinos.de

**Austria**

Pfeiffer Vacuum Austria GmbH  
Vienna  
office@pfeiffer-vacuum.at

**Benelux**

Pfeiffer Vacuum Benelux B.V.  
Culemborg, Netherlands  
office@pfeiffer-vacuum.nl

**Brazil**

Pfeiffer Vacuum Brasil Ltda.  
São Paulo  
info@pfeiffer-vacuum.com.br

**China**

Pfeiffer Vacuum  
(Shanghai) Co., Ltd.  
Shanghai  
info@pfeiffer-vacuum.cn

**France**

adixen Vacuum Products  
Annecy  
info@adixen.com

**India**

Pfeiffer Vacuum India Ltd.  
Secunderabad  
pvin@pfeiffer-vacuum.in

**Italy**

Pfeiffer Vacuum Italia S. p. A.  
Paderno Dugnano  
contact@pfeiffer-vacuum.it

**Romania**

Admin Manufacturing,  
Romania SRL.  
Cluj-Napoca  
info@adixen.ro

**Scandinavia**

Pfeiffer Vacuum Scandinavia AB  
Upplands Väsby  
Sweden  
sales@pfeiffer-vacuum.se

**Singapore**

Pfeiffer Vacuum  
Singapore Pte. Ltd.  
Singapore  
info@pfeiffer-vacuum.sg

**South Korea**

Pfeiffer Vacuum Korea Ltd.  
Yongin City, Kyungki-Do  
sales@pfeiffer-vacuum.co.kr

adixen Vacuum Technology  
Korea, Ltd.  
Hwasung-Si, Gyeonggi-Do  
sales@adixen.co.kr

**Switzerland**

Pfeiffer Vacuum (Schweiz) AG  
Zurich  
info@pfeiffer-vacuum.ch

**Taiwan R.O.C**

Pfeiffer Vacuum Taiwan  
Corporation Ltd.  
Hsin-Chu County  
info@pfeiffer-vacuum.tw

**United Kingdom**

Pfeiffer Vacuum Ltd.  
Newport Pagnell, England  
sales@pfeiffer-vacuum.co.uk

**USA**

Pfeiffer Vacuum Inc.  
Nashua, NH  
contact@pfeiffer-vacuum.com

## Masthead

### **Pfeiffer Vacuum GmbH**

April 2013

Subject to change without notice

Price: € 60.00

Vacuum Technology Book Volume II: PI 0355 PEN

Part 1 – Vacuum solutions from a single source PI 0355\_1 PEN

### **Photo credits**

Pfeiffer Vacuum GmbH: Product images and drawings

ESO/S. Brunier

Fotolia.com: © TM – Design / © Alan Z. Uster / © Schlierner /

© Alexander Raths / © Harald Biebel / © doris\_bredow / © LVDESIGN /

© Vladislav Kochelaevs / © chilly / © Vladitto / © Thomas Francois /

© sil007 / © lapas77 / © msl33 / © industrieblick / © Iakov Kalinin /

© Picture-Factory / © Günter Menzl / © Gerhard Seybert / © visdia /

© Rynio Productions / © JohanSwanepoel

### **Product photos**

Fotostudio Gleim, 35452 Heuchelheim, Germany

### **Publisher and party responsible for content**

Pfeiffer Vacuum GmbH

Berliner Strasse 43

35614 Asslar, Germany

T +49 6441 802 0

F +49 6441 802 1202

info@pfeiffer-vacuum.de

www.pfeiffer-vacuum.com

### **Design**

Filusch & Fiore Werbeagentur GmbH, 35423 Lich, Germany

### **Printing**

mSP druck und medien gmbh, 57555 Mudersbach, Germany

### **Note**

The Vacuum Technology Book Volume II, effective April 1, 2013

Regardless of their nature, the information and promotional statements contained in this product catalog and, in particular, the descriptions, photographs, illustrations, drawings, samples and information relating to quality, nature, composition, performance, consumption and usability, as well as the dimensions and weights of the product portfolio, are subject to change without notice if not expressly designated as being definitive. Such information does not represent any assurance or warranty commitment of any kind. Minor deviations from the product information shall be deemed to be accepted if they are not unreasonable for the purchaser. We expressly reserve the right to correct errors and modify technical information.